







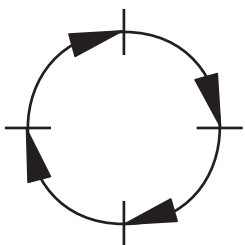

ROTOMATION^{INC}

THE SHAFT MOTIONS COMPANY

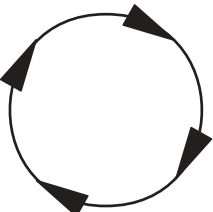

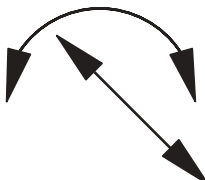
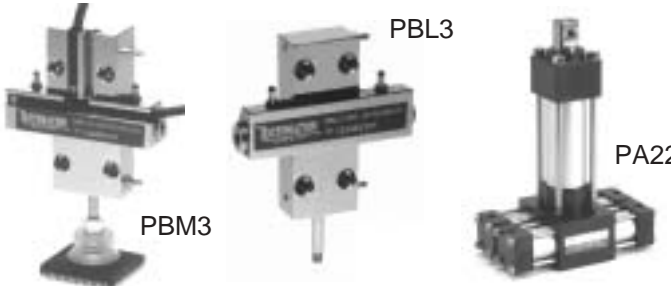
FLUID POWER FOR AUTOMATION

<p>ROTARY ACTUATORS</p> 	<p>Back and Forth Windshield Wiper Motion</p> <p>Optional Stops at Multiple Positions in any Sequence</p>	 <p>A032 A42 A752</p>
<p>INDEXING ACTUATORS</p> 	<p>One Way Rotation in Steps to Hard Stops</p> <p>Steps 12 to 360 Degrees</p> <p>No Accumulating Error</p>	 <p>X4 X1</p>
<p>STEPPING ACTUATORS</p> 	<p>One Way Rotation in Steps Without Hard Stops</p> <p>Steps in Any Angle Available</p>	 <p>S4 S1</p>
<p>PICK & PLACE ACTUATORS</p> 	<p>Back and Forth Rotation, Extend and Retract</p> <p>Independently Driven</p> <p>Miniature with Vacuum Through Rod</p>	 <p>PBM3 PBL3 PA22</p>
<p>OPTIONS FOR ACTUATORS</p>	<p>Control Motion</p> <p>Special Construction</p> <p>Magnetic Switches</p> <p>Mount Plates</p> <p>Shaft Configuration</p>	
<p>OTHER PRODUCTS</p>	<p>Shaft Mounting Adapters</p> <p>Hydraulic Swing Clamp</p>	

DIRECTORY

CONVEYOR DIVERTERS

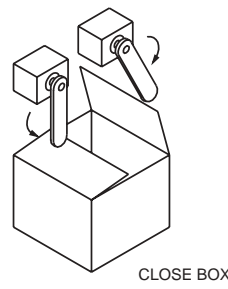
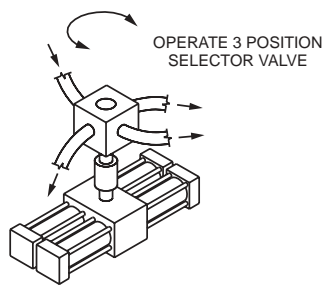
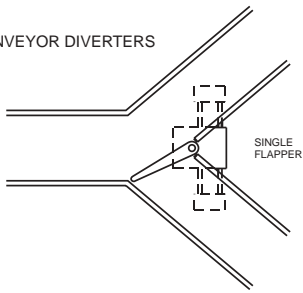

Miniature Actuators	6
OEM Miniature Actuators	10
Compact Actuators	12
5/8" Bore Tie Rod Actuators	14
1" to 2" Bore Tie Rod Actuators	18

INDEXING BOTTLE FILL

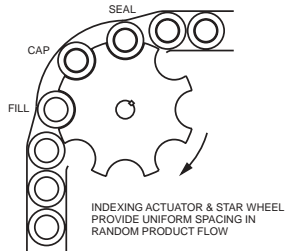

4 STATION INDEX TABLE

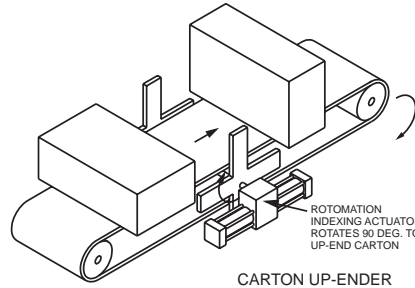
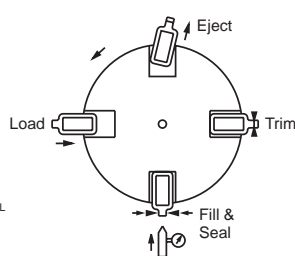

Indexing Actuators	24
--------------------	----

DISPENSE ADHESIVE

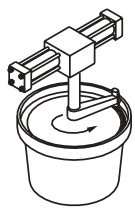

RIBBON FEED

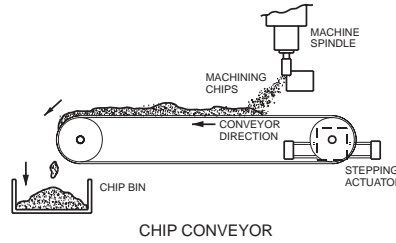
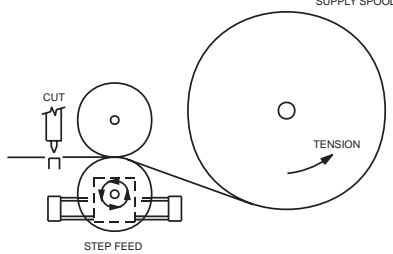

Stepping Actuators	30
--------------------	----

PICK AND PLACE

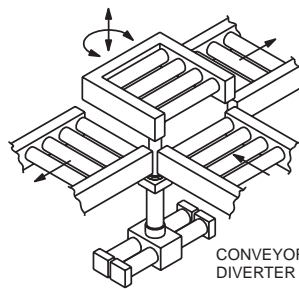
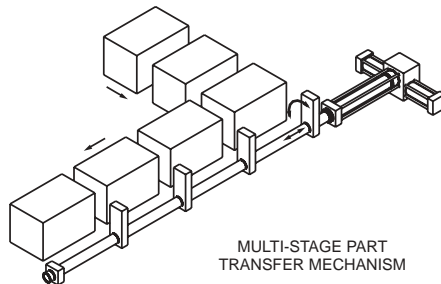
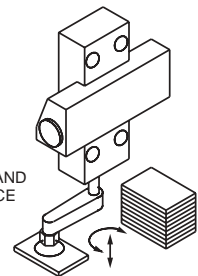

Miniature with Vacuum	32
Parts Handling	34

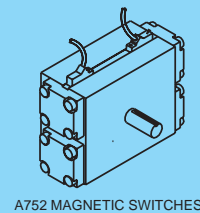
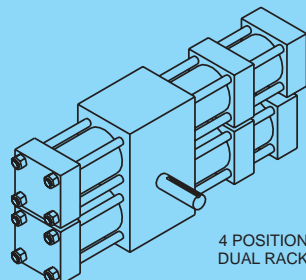
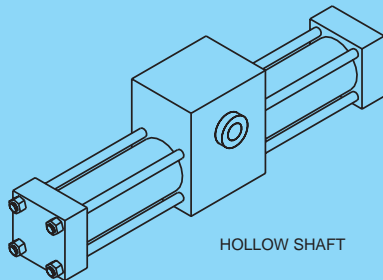

Options	38
---------	----

EASY TURNTABLE MOUNT

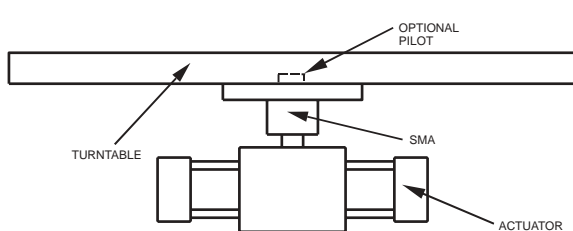

MACHINE CLAMPING

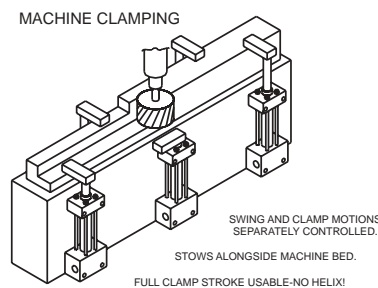

Shaft Mounting Adapters	44
Hydraulic Swing Clamp	45

Don't live with "one size fits all"

Select a shaft motion

Pick a basic unit

Specify options that serve you best

Get delivery in five days

Pay an off the shelf price

Run reliable production

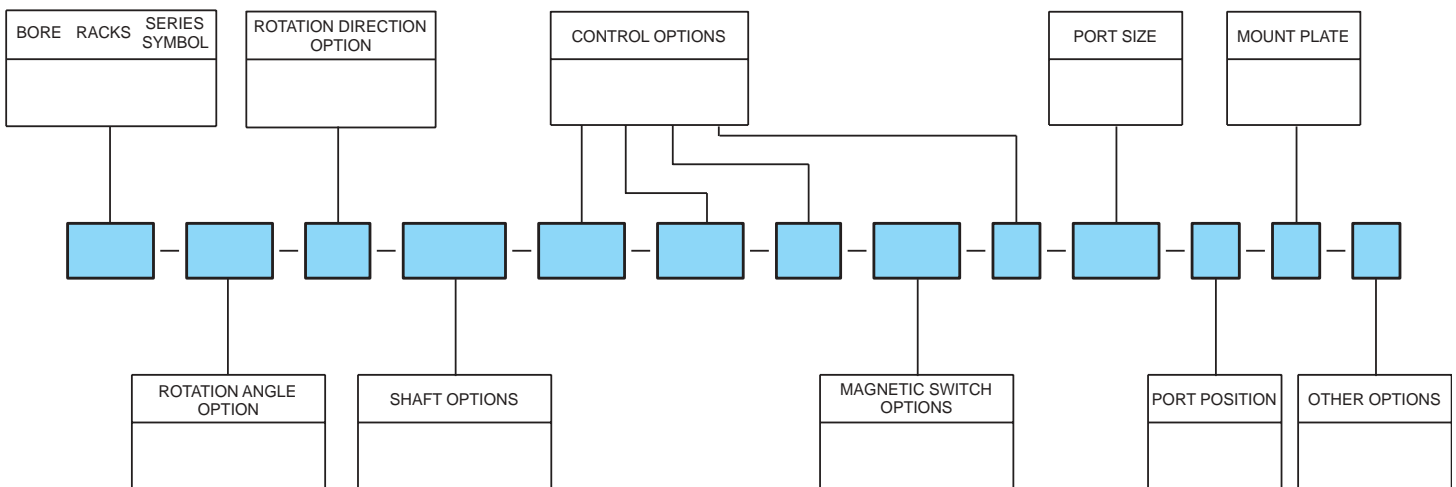

Optimize your application with multiple choices for most parameters; 150 billion standard combinations!

Specials? Send us your sketch and we will quote you one or one thousand.

On time delivery

ROTOMATION INC. builds
actuators, stepping actuators and indexing actuators
of proven materials, components and design

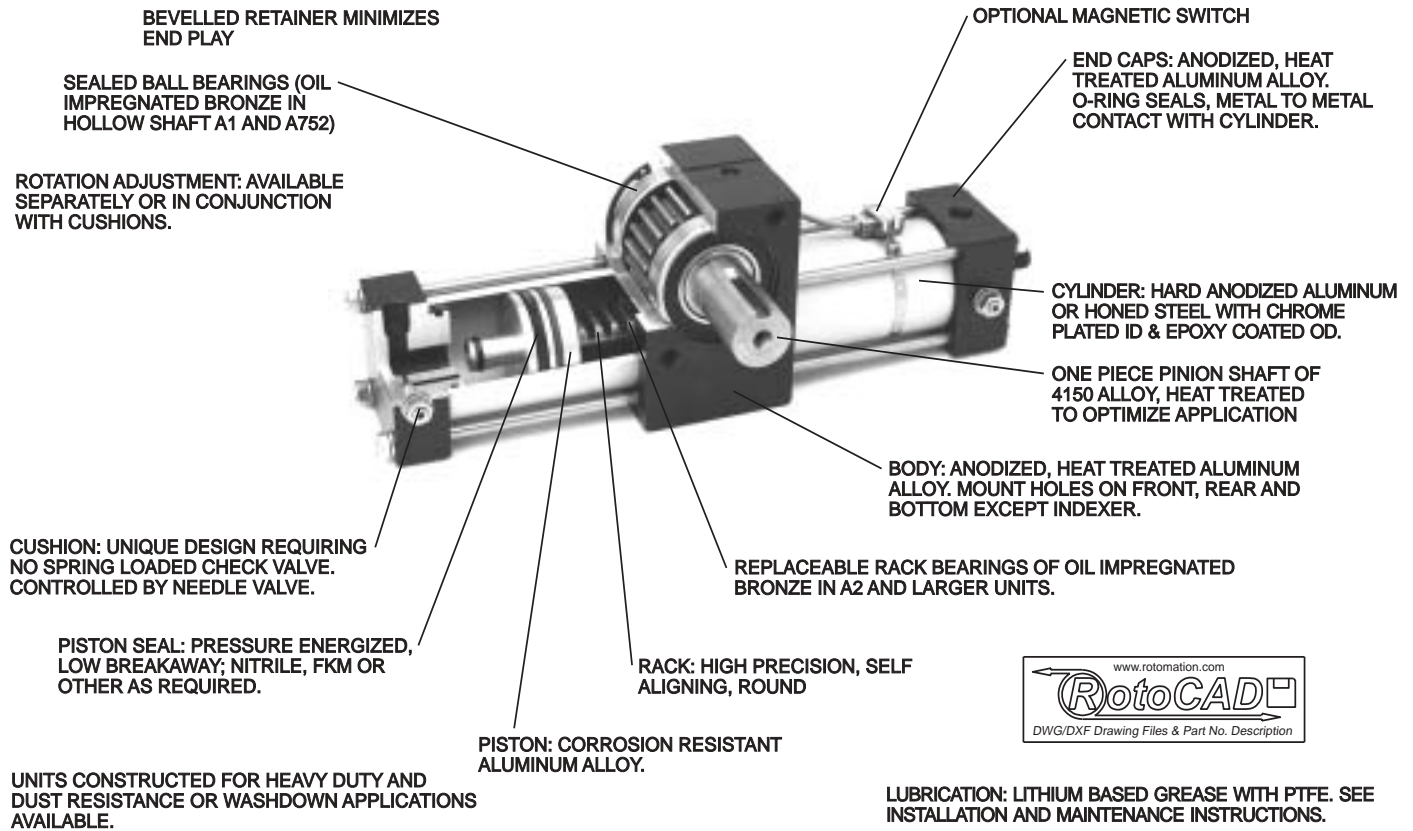

Performance you can count on

All Rotomation devices except AL75 are of rack and pinion construction to provide a constant torque over entire rotation of their shafts. Their similarities and differences are outlined in the following table.

OPERATION	COMPOSITE UNITS							
	ROTARY ACTUATOR	STEPPING ACTUATOR	INDEXING ACTUATOR	PICK & PLACE ACTUATOR	NITPICKER (INDEXER)			
Shaft Rotation	Back and Forth	One Way	One Way	Back & Forth	One Way			
Rotation Tolerance	A032, A01 A752, A1, A12 A2, A22 A3, A32, A4, A42	-0+5 -0+2 -0+3 -0+2	N/A	All: -0.2	PA01 PA2, PA22 PA3, PA32	-0+10 -0+3 -0+2	PX2 PX22	-0.2 -0.2
Backlash at end of rotation	ALL DUAL RACK A01 A1, A2 A3, A4	0 2 1 .5	N/A	All: 0	PA01 PA2, PA3 PA22, PA32	6 2 1	PX2	1
Variable Rotation	Optional	Optional	No	Std. On PBL3 & PBM3 optional on others	No			
Multiple Angles of Rotation	Optional except AL75	Optional	Optional	Optional except PBL3 & PBM3	Optional			
Shaft Extension and Retraction	No	No	No	Yes	Yes			
Breakaway pressure with standard seals	5 psi	5 psi	7 psi	12 psi	12 psi			

DESIGN YOUR A032 ROTARY ACTUATOR

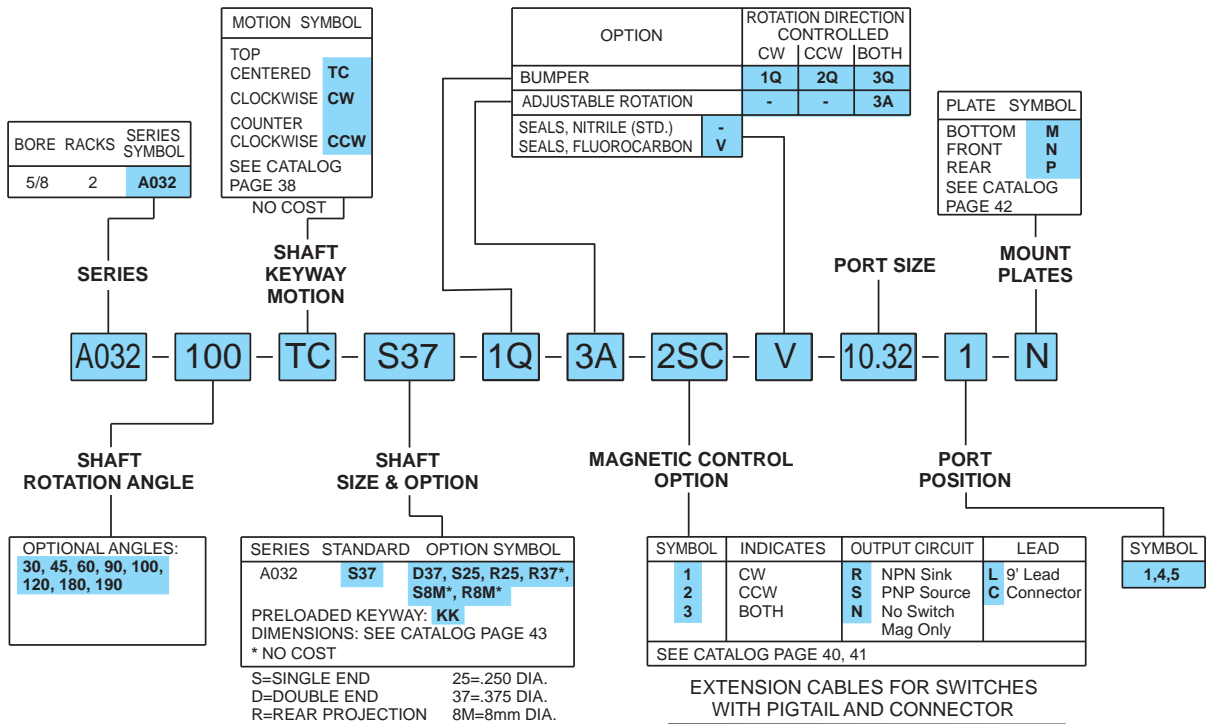

SEAL REPAIR KITS
FILL IN UNIT SERIES AND ALL RELATED OPTIONS:

SRK - [A032] - [A] - [V]
SERIES ROTATION SEALS
ADJUSTERS

EXAMPLE:
SEAL KIT FOR A032-100-TC-S37-1Q-3A-2SC-V-10.32-1-N = SRK-A032-A-V

NOTE: IF NO OPTIONS, SPECIFY SRK-A032-STD.

CALCULATED TORQUE IN INCH-POUNDS
Deduct 10% for friction

OPERATING PRESSURE IN PSI						
25	50	60	80	100	200	300 (HP)
2.9	5.8	6.9	9.2	11.5	-	-

DESIGN YOUR A032 THREE POSITION ROTARY ACTUATOR

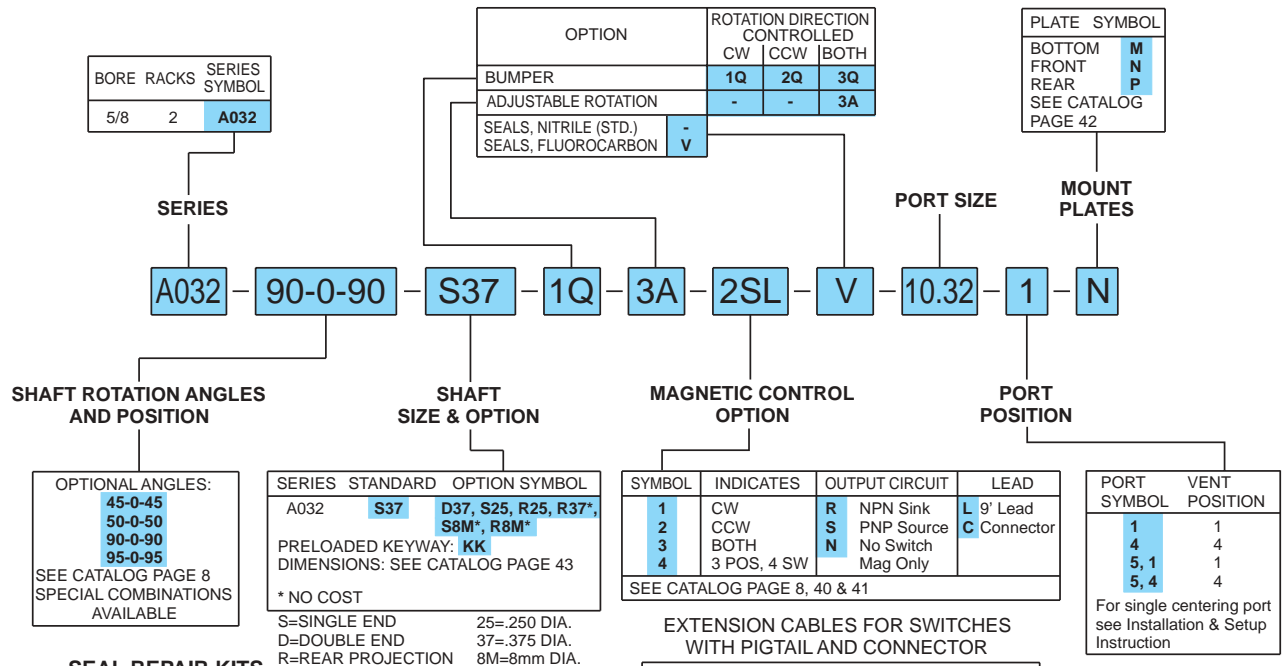

SEAL REPAIR KITS
FILL IN UNIT SERIES AND ALL RELATED OPTIONS:

SRK - [A032] - [90-0-90] - [A] - [V]
SERIES ANGLES/ ROTATION SEALS
POSITION ADJUSTERS

EXAMPLE:
SEAL KIT FOR A032-90-0-90-S37-1Q-3A-2SL-V-10.32-1-N = SRK-A032-90-0-90-A-V

NOTE: IF NO OPTIONS, SPECIFY SRK-A032-90-0-90-STD.

A032 SUBMINIATURE DUAL RACK ACTUATOR

THE MIGHTIEST MINI -- THE MOST TORQUE FOR ITS SIZE

PICTURED ACTUAL SIZE



DOUBLE ENDED SHAFT OPTION
OR REAR SHAFT PROJECTION

TOP VIEW

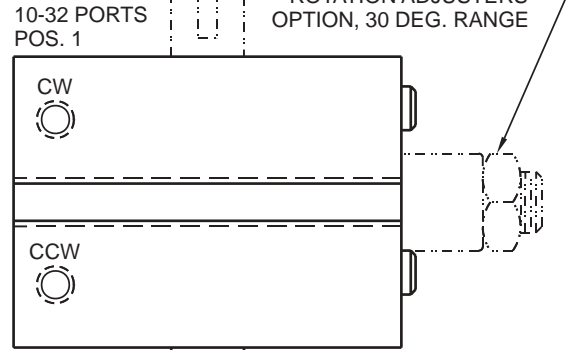

.375 DIA.
(.250 DIA. OPT. DET. 'Z')

3/32 x 3/64

MAGNETIC SWITCH OPTION

10-32 PORTS POS. 5

END VIEW

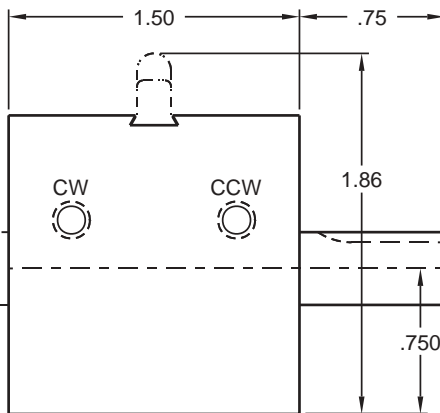

(2) 10-32 X 3/8 DP. TYP. FRONT & REAR

10-32 PORTS POS. 4

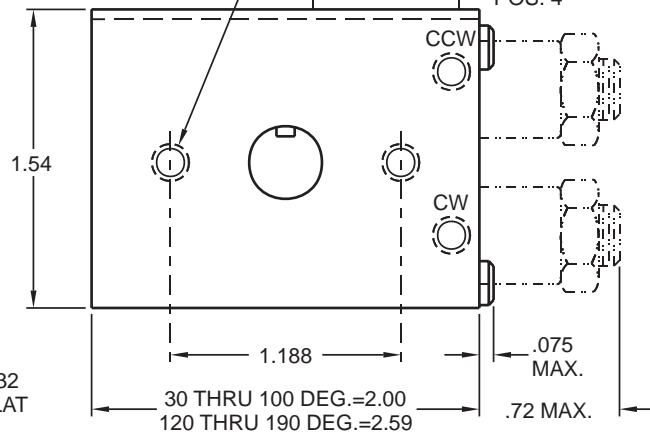

FRONT VIEW

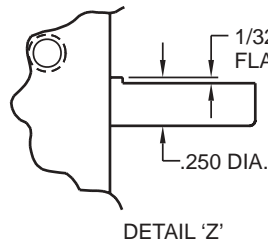

(4) 10-32 X .38 DP. BOTTOM ONLY

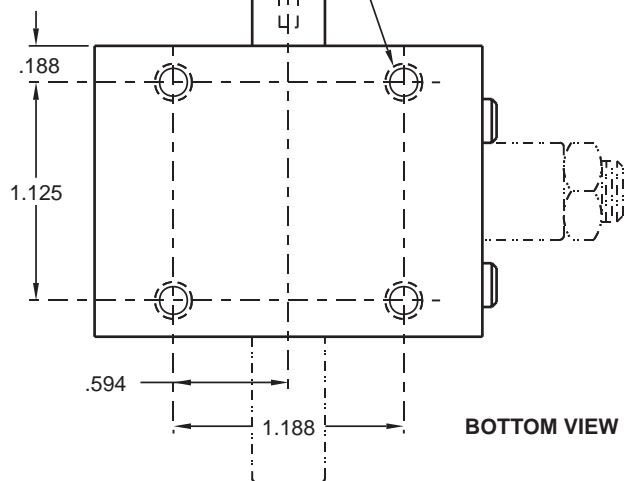

RATINGS

Torque Factor: in. lb./p.s.i.	.115
Max. Working Pressure, p.s.i.:	130
Max. Torque: Non-shock, in. lb.	15
Max. Thrust: Non-shock, lb.	30
Max. Radial Load: Non-shock, lb.	40
Displacement: in ³ /deg.	.002
Weight std. unit 90 deg: lb.	0.5
Backlash at ends of rotation	0

NOTE:

1. The position of the ports and adjusters relative to the shaft can be changed by specifying rear projecting shaft.
2. 10-32 ports will accept M5X.8 fittings.
3. For plumbing and magnetic switch system setup, request guide.

A032 SUBMINIATURE THREE POSITION ACTUATOR

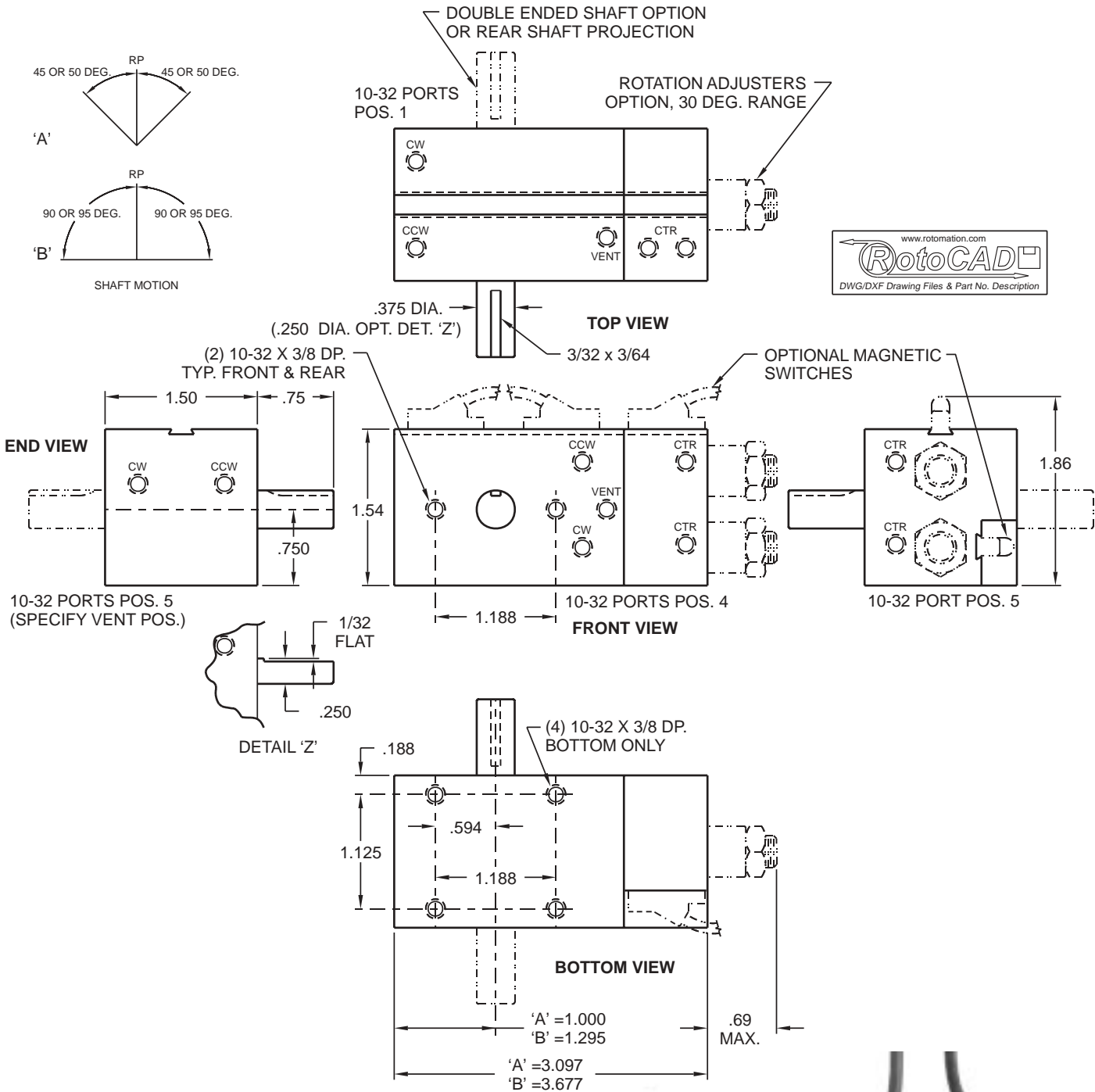

RATINGS

Torque Factor to end position: in. lb./p.s.i.	.115
Torque Factor to center: in. lb./p.s.i.	.057
Max. Working Pressure, p.s.i.:	130
Max. Torque: Non-shock, in. lb.	15
Max. Thrust: Non-shock, lb.	30
Max. Radial Load: Non-shock, lb.	40
Displacement: in ³ /deg.	.002
Weight std. 90 deg. unit: lb., "A" above	0.8
Backlash at ends of rotation	0

NOTES:

- The position of the ports and adjusters relative to the shaft can be changed by specifying rear projecting shaft as shown in photo.
- 10-32 ports will accept M5X.8 threads.
- For plumbing and magnetic switch system setup, request guide. Note that (4) magnetic switches are required to sense all (3) positions.



APPLICATIONS ROTOMATION DOES BETTER MORE PRECISELY

**CONVEYOR STOP
USING 90 ROTARY ACTUATOR**

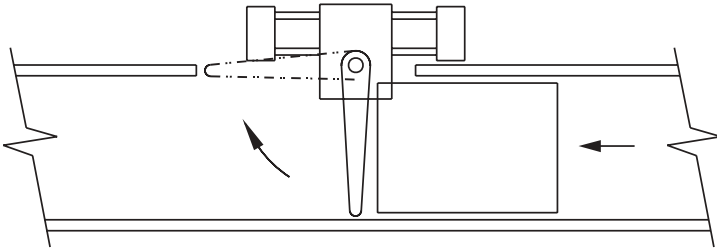

**CARTON ORIENT USING
4 POS. ROTARY ACTUATOR**

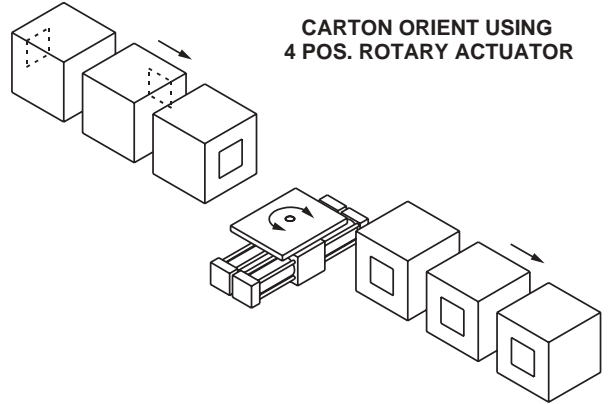

**OVER CENTER LOAD
SWING-NO IMPACT**

**ALL AIR-NO OIL-NO SHOCK
ABSORBERS WORKS AT
HIGH CYCLE RATES.**
Over Center or Other High
Inertia Load Control.

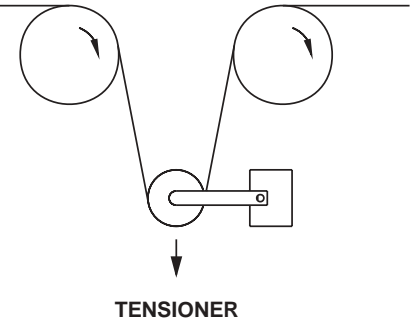
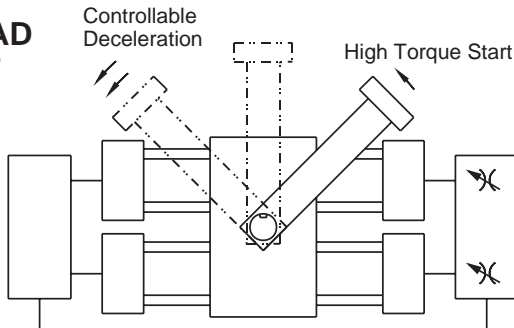

TUBE BENDER

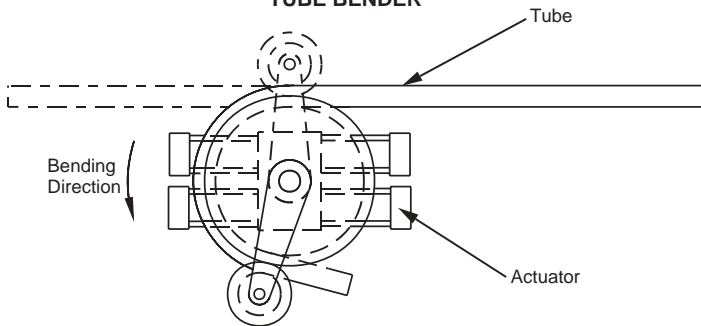

**FLIP CIRCUIT BOARD
FOR COMPONENT INSTALLATION
BOTH SIDES**

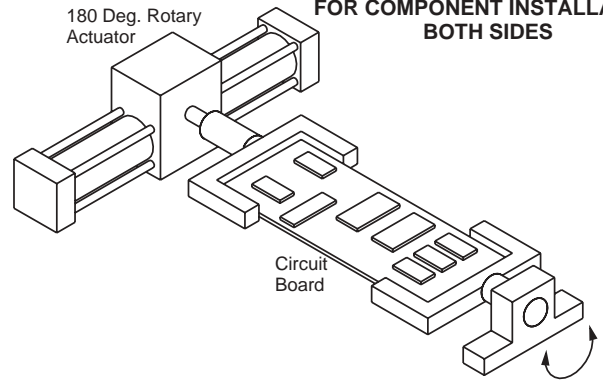

**PICK & PLACE
PARTS**

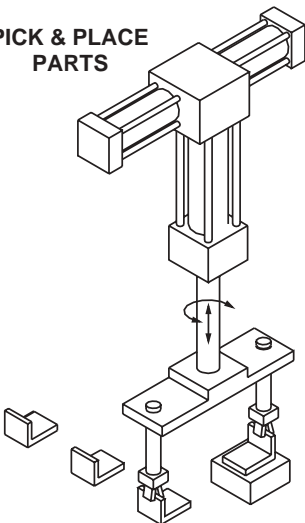

**RIVET FEED
& INSTALL**

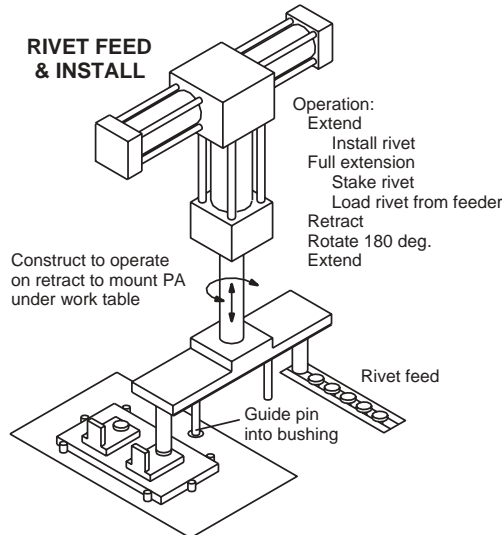

SORTING

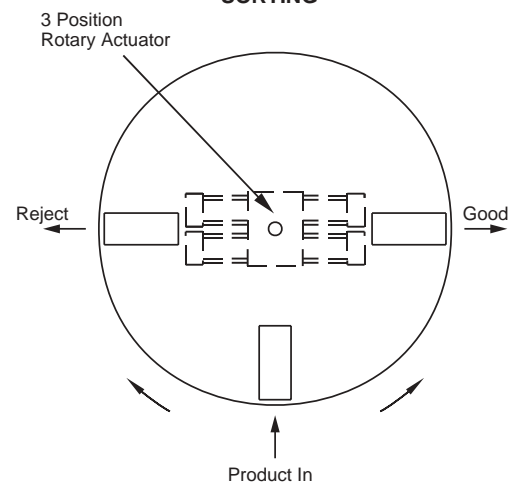

DESIGN YOUR AL75 ROTARY ACTUATOR

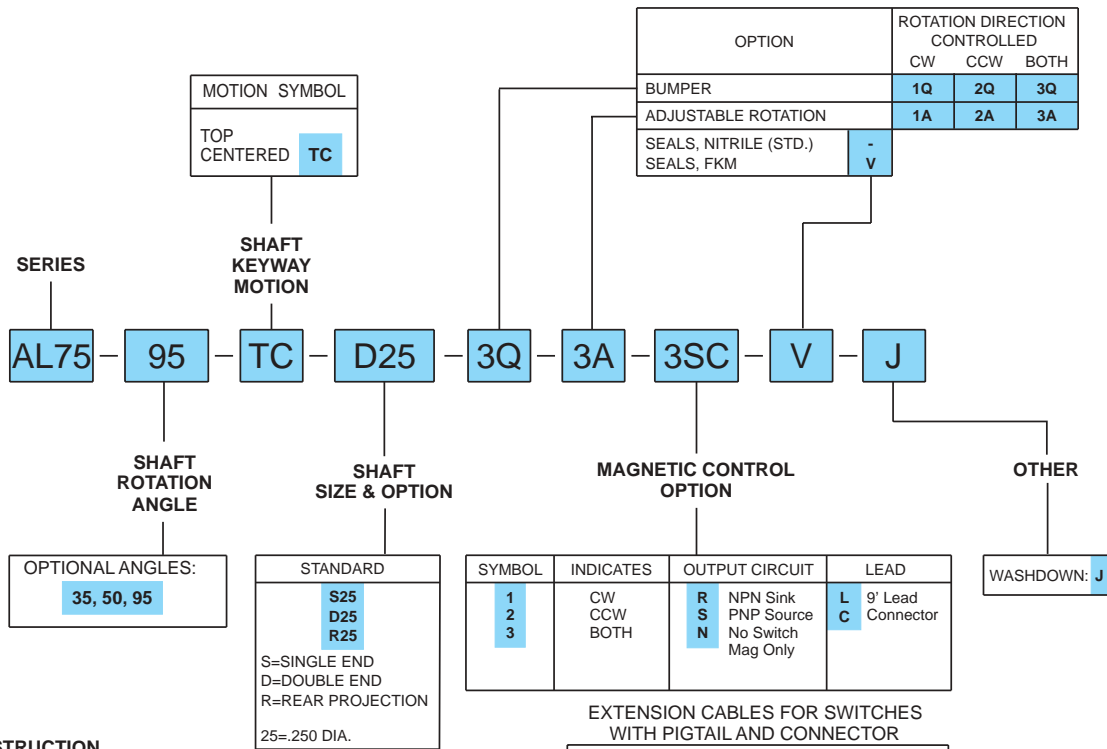

AL75 CONSTRUCTION

One-piece, double ended piston drives shaft lug.

Shaft torque and angular velocity vary over rotation angle. Torque and velocity both low at ends of stroke to provide gentle start and stop.

Shaft lug shape and piston groove contour held to close tolerance for low friction and long life. Units tested under load beyond 20 million cycles without lubrication and without appreciable wear. Piston configuration is stable in cylinder bore, preventing localized wear.

Maximum rotation is about 95 deg., limited by geometry of drive system.

Piston is of internally lubricated PBT plastic, a stable, low friction, non-absorbent, high impact strength material. Body, including cylinder bore, is aluminum (6061) hardcoat anodized. Shaft is electroless nickel plated steel.

Ideal for food processing or clean room applications. Stainless steel or PET construction available on special order.

Washdown J option has plain bearing of PET instead of standard ball bearing.

EXTENSION CABLES FOR SWITCHES WITH PIGTAIL AND CONNECTOR

ORDER SEPARATELY	
CABLE	PART NUMBER
2 METER LENGTH	CC2
5 METER LENGTH	CC5

SEAL REPAIR KITS

PART NUMBERS FOR SEAL REPAIR KITS

FILL IN UNIT SERIES AND ALL RELATED OPTIONS:

SRK - [AL75] - [A] - [V] - [J]
 SERIES ROTATION SEALS WASHDOWN
 ADJUSTERS

EXAMPLES:
 SEAL KIT FOR AL75-95-TC-D25-3Q-3A-V = SRK-AL75-A-V
 NOTE: IF NO OPTIONS, SPECIFY SRK-AL75-STD.

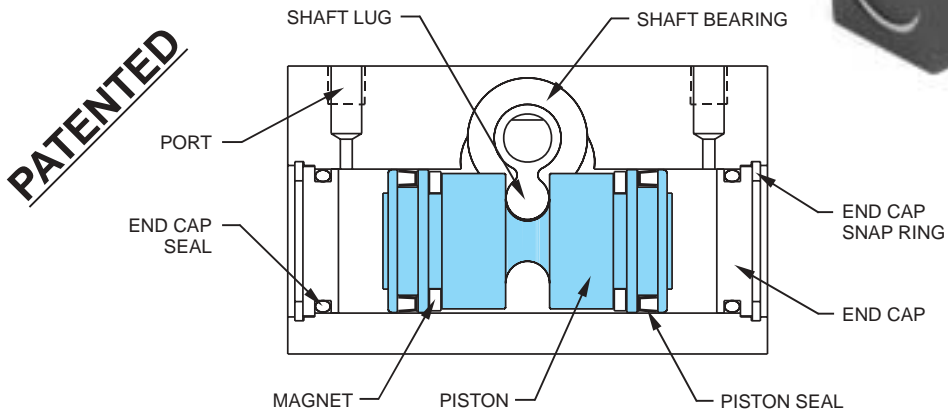

AL75 ROTARY ACTUATOR

PICTURED ACTUAL SIZE



PATENTED

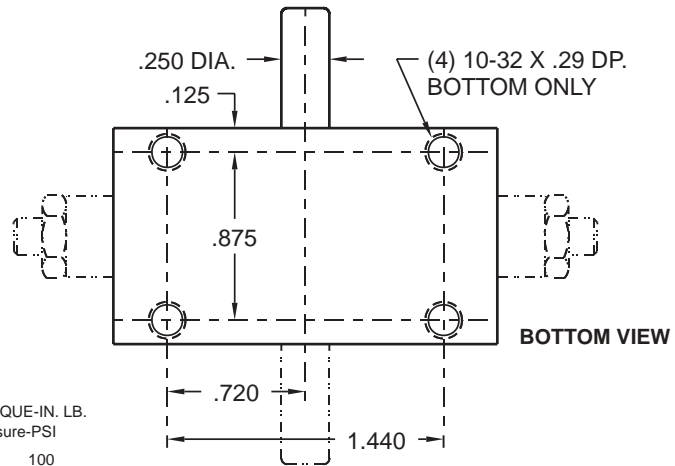
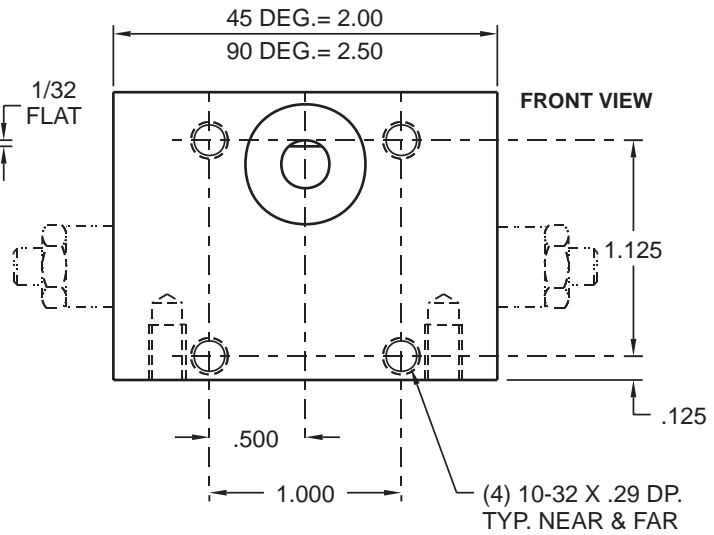
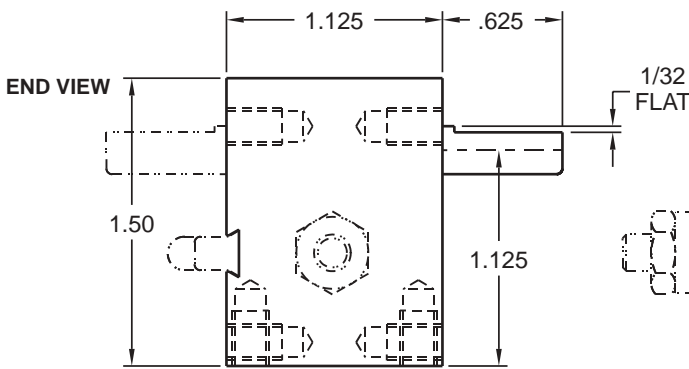
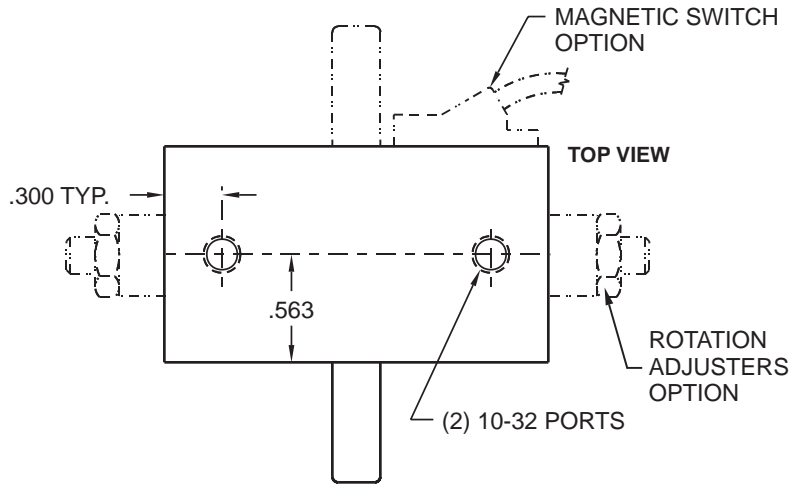

RATINGS

Max. Working Pressure: p.s.i.:	100
Max. Torque: Non-shock: in. lb.	14
Max. Load Energy: in. lb.	.25 in. lb.
Max. Thrust Load: lb.	20
Max. Radial Load: lb.	20
Displacement: in ³ /deg.	.0012
Weight std. unit 90: lb.	0.3
Backlash at ends of rotation: deg.	1

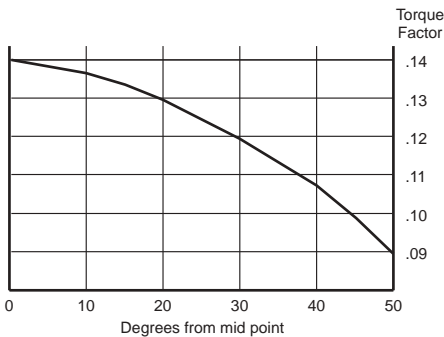

CALCULATED TORQUE-IN. LB.

Operating pressure-PSI

	60	80	100
Factor .14	8.4	11.2	14
Factor .13	7.8	10.4	13
Factor .12	7.2	9.6	12
Factor .11	6.6	8.8	11
Factor .10	6	8	10
Factor .09	5.4	7.2	9



DESIGN YOUR A752 ROTARY ACTUATOR

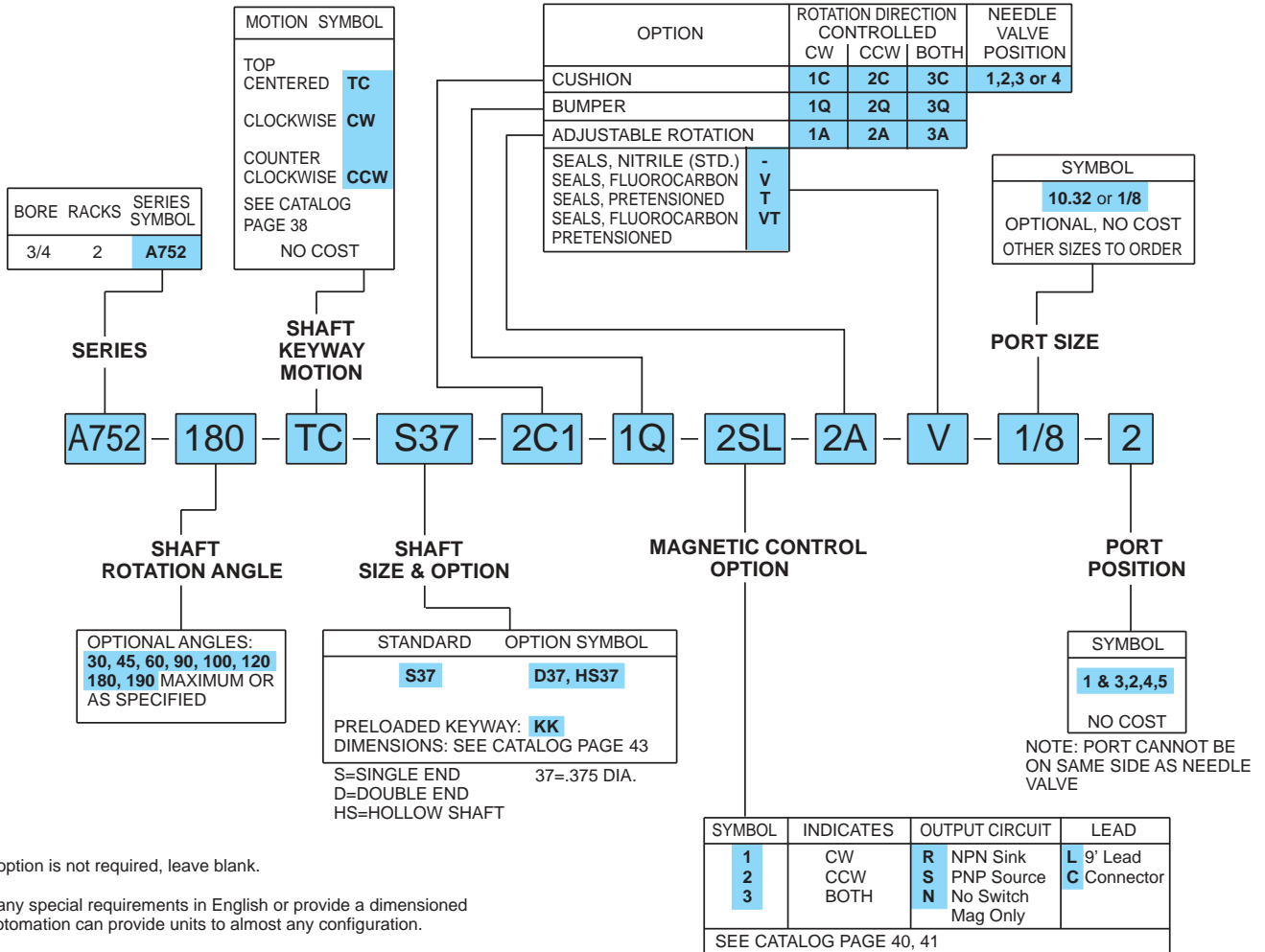

When an option is not required, leave blank.

Write out any special requirements in English or provide a dimensioned sketch. Rotomation can provide units to almost any configuration.

To expedite the order of a duplicate of a prior unit, refer to prior invoice/serial number stamped on the unit body.

Needle valve cannot be on same side as port.

CALCULATED TORQUE IN INCH-POUNDS

Deduct 10% for friction

OPERATING PRESSURE IN PSI						
25	50	60	80	100	200	300 (HP)
11	22	26.6	35.4	44.2	-	-

FEATURES

- High torque: .44P in. lb.
- Ball bearings
- Compact size
- Roller burnished long life cylinder bores
- Mounts on base, front or rear face
- No backlash at ends of rotation



EXTENSION CABLES FOR SWITCHES WITH PIGTAIL AND CONNECTOR

ORDER SEPARATELY	
CABLE	PART NUMBER
2 METER LENGTH	CC2
5 METER LENGTH	CC5

SEAL REPAIR KITS

PART NUMBERS FOR SEAL REPAIR KITS

FILL IN UNIT SERIES AND ALL RELATED OPTIONS:
SRK - **A3** - **C** - **A** - **VT**
SERIES CUSHIONS ROTATION SEALS
ADJUSTERS

EXAMPLES:
SEAL KIT FOR A752-180-TC-S37-2C1-1Q-2SL-2A-V-1/8-2 = SRK-A752-C-A
NOTE: IF NO OPTIONS, SPECIFY SRK-A752-STD.

A752 COMPACT, HIGH TORQUE DUAL RACK ACTUATOR

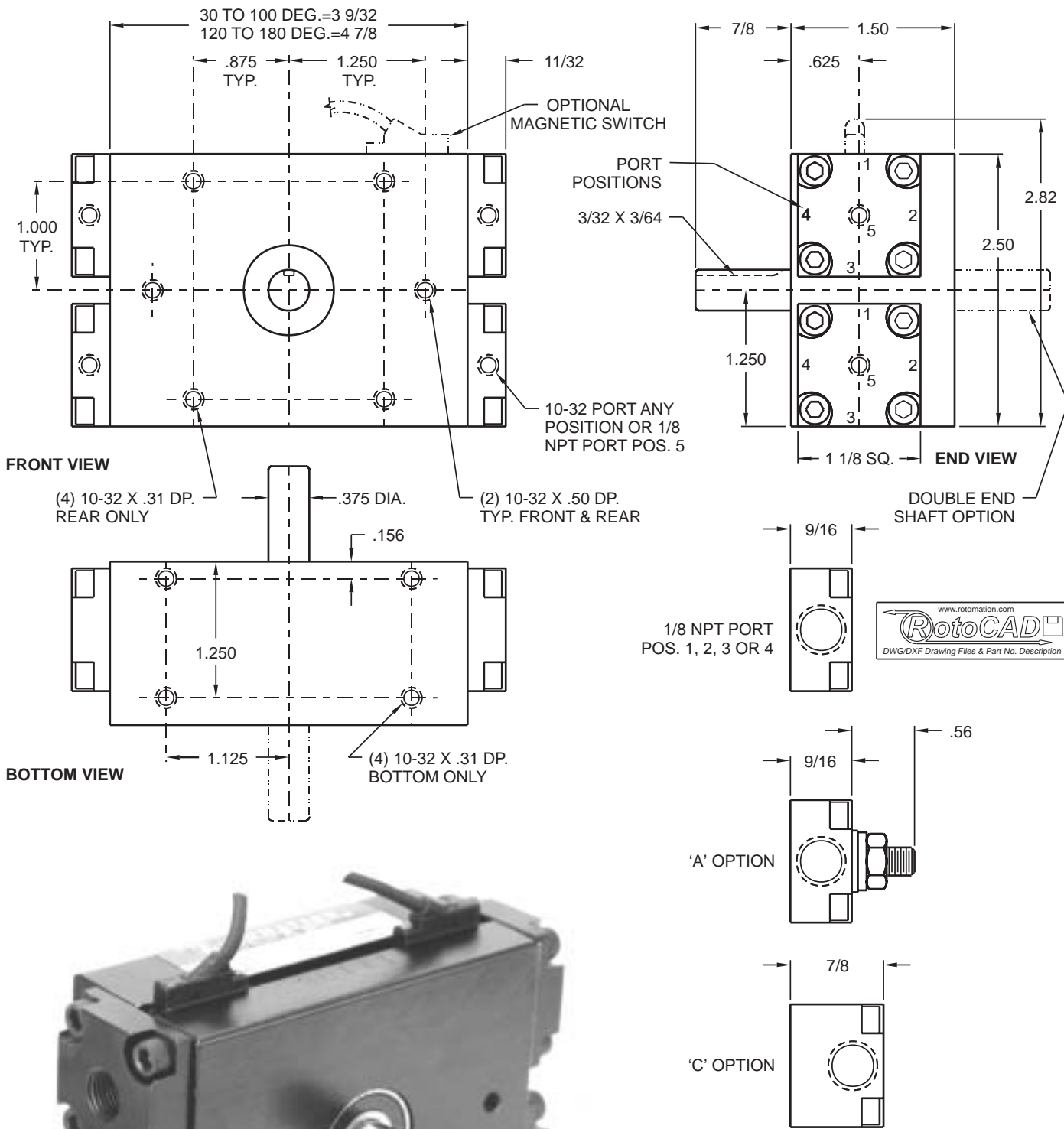

RATINGS

Torque Factor: in. lb./p.s.i.		.44
Max. Working Pressure, p.s.i.:	Air	150
	Oil	150
Max. Torque: Non-shock, in. lb.		70
Max. Thrust: Non-shock, lb.		40
Max. Radial Load: Non-shock, lb.		40
Displacement: in ³ /deg.		.0078
Weight 180 deg. std. unit: lb.		1.9

NOTE:
Unit should not be subjected to torque impacts, as those from a high momentum load, without external stops.

DESIGN YOUR 5/8 BORE TIE ROD ROTARY ACTUATOR

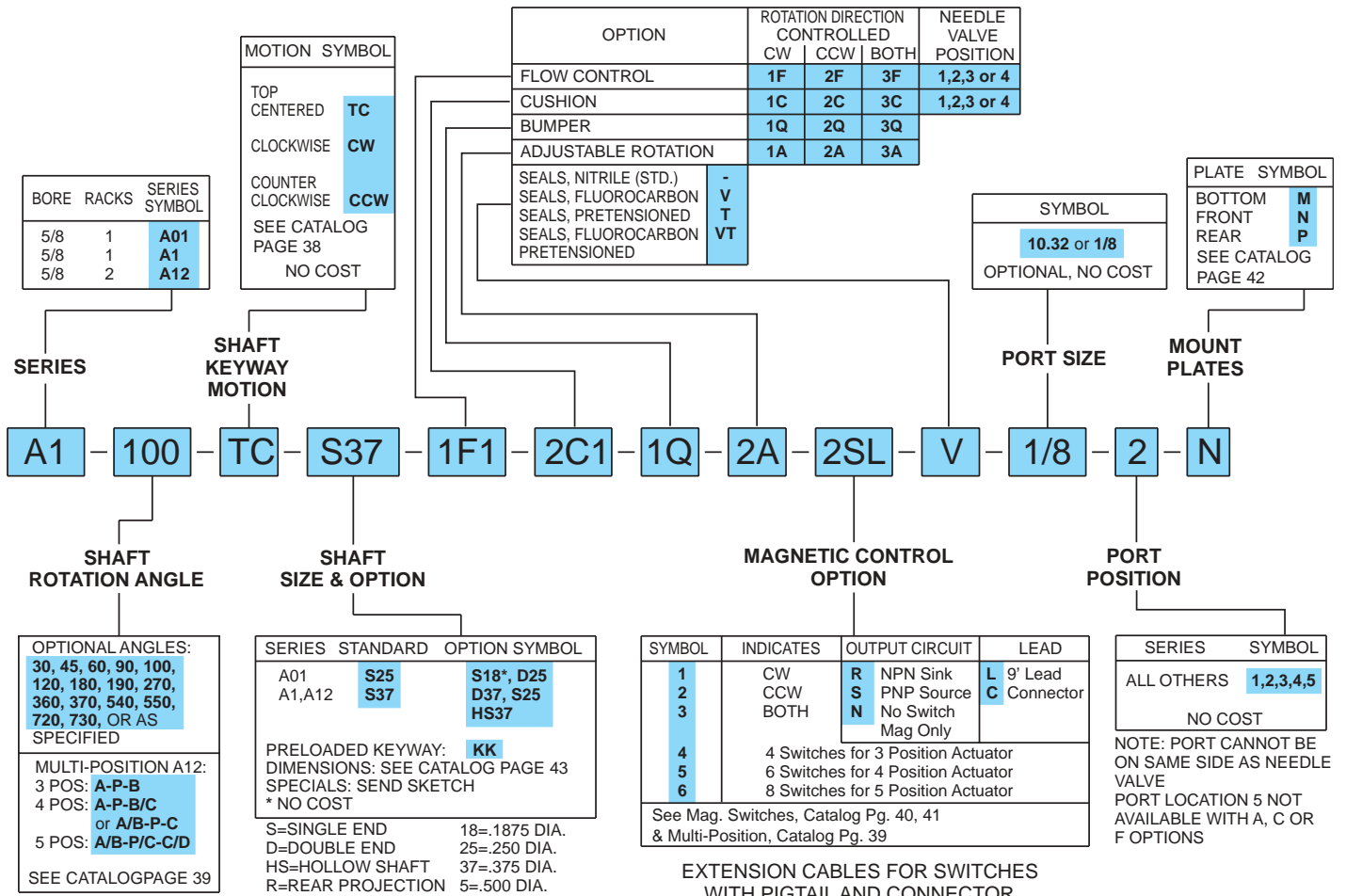

When an option is not required, leave blank.

Write out any special requirements in English or provide a dimensioned sketch. Rotomation can provide units to almost any configuration.

To expedite the order of a duplicate of a prior unit, refer to prior invoice/serial number stamped on the unit body.

Flow control and cushion cannot be installed in same end cap. Flow control in A01, A1, A12 10.32 port only.

Needle valve cannot be on same side as port.

See Mag. Switches, Catalog Pg. 40, 41 & Multi-Position, Catalog Pg. 39

EXTENSION CABLES FOR SWITCHES WITH PIGTAIL AND CONNECTOR

ORDER SEPARATELY	
CABLE	PART NUMBER
2 METER LENGTH	CC2
5 METER LENGTH	CC5

CALCULATED TORQUE IN INCH-POUNDS

Deduct 10% for friction

UNIT	OPERATING PRESSURE IN PSI					
	25	50	60	80	100	200
A01	1.9	3.8	4.6	6.2	7.7	-
A1	3.8	7.6	9.2	12.3	15.3	30.7
A12	7.6	15.2	18.4	24.6	30.6	-

SEAL REPAIR KITS

PART NUMBERS FOR SEAL REPAIR KITS

FILL IN UNIT SERIES AND ALL RELATED OPTIONS:

SRK - [A12] - [90-0-90] - [F] - [C] - [A] - [V]
 SERIES ANGLES/POSITION FLOW CUSHIONS ROTATION SEALS
 IF MULTI-POSITION CONTROL ADJUSTERS

EXAMPLES:

SEAL KIT FOR A12-90-0-90-S37-3F1-1/8-2 = SRK-A12-90-0-90-F

NOTE: IF NO OPTIONS, SPECIFY SRK-A12-STD.

A01 ROTARY ACTUATOR

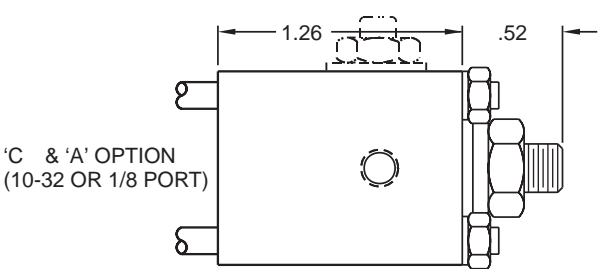
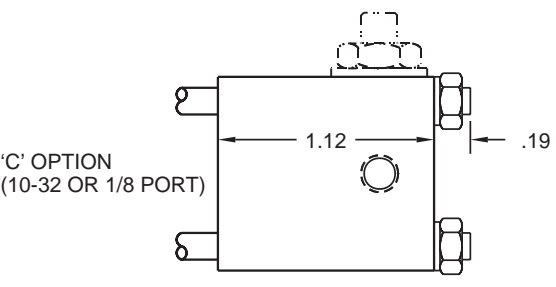
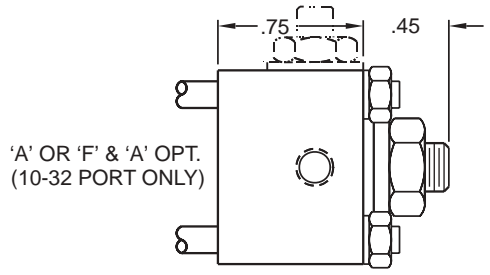
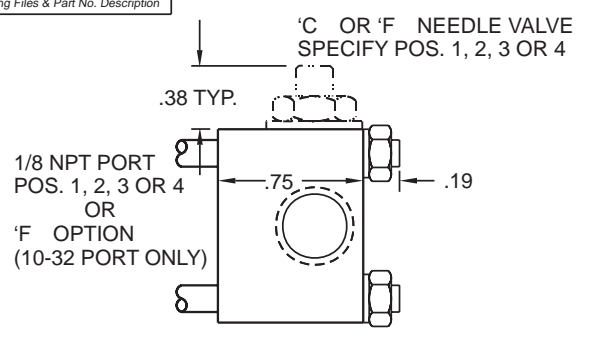
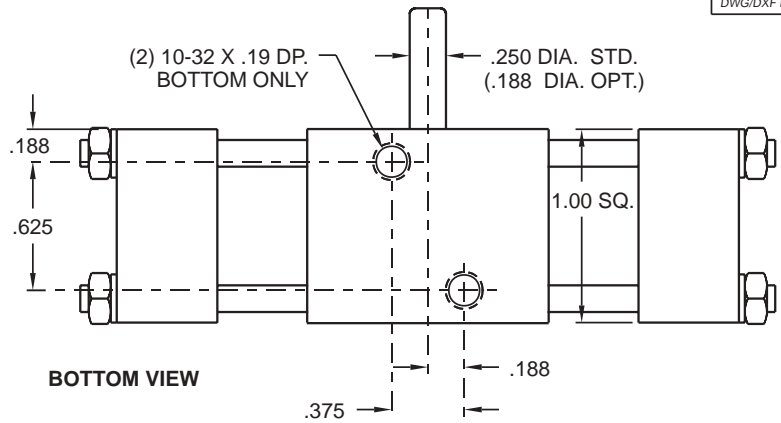
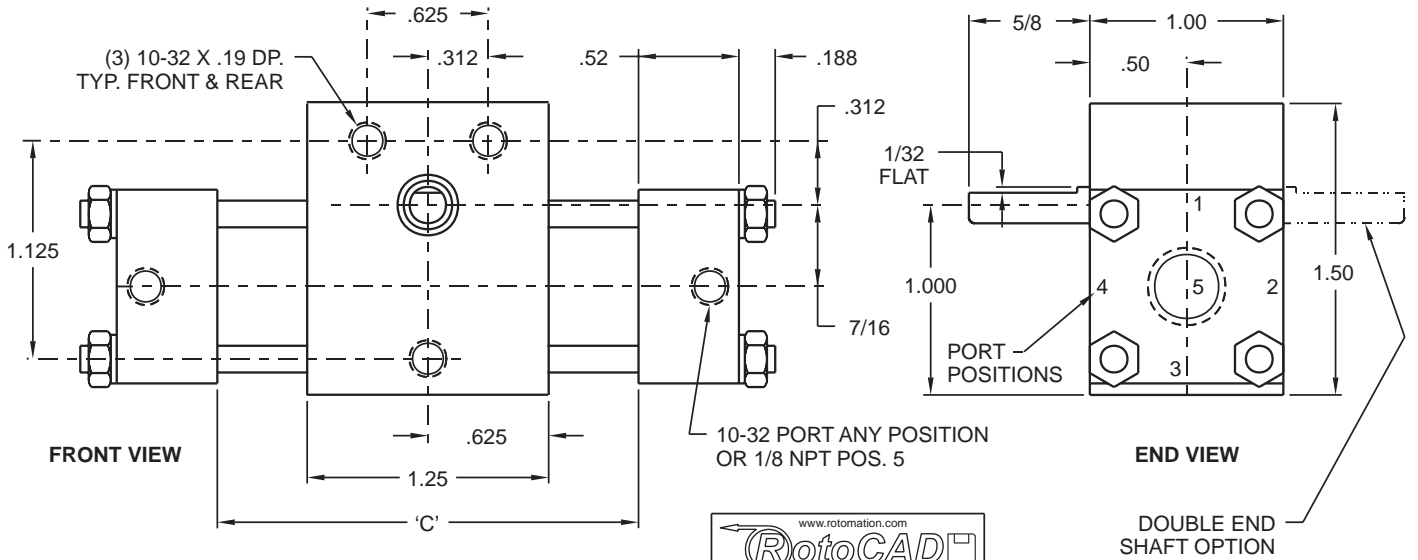

ROTATION	'C' DIMENSION		ADD TO 'C' DIM. PER SIDE	
	STD.	'R' OR 'S' OPT.	'Q' OPTION	'Q' & 'A' OPTION
30 DEG.	1.36	4.06	.06	.13
45	1.49	4.13		
60	1.62	4.20		
90	1.89	4.20		
100	1.97	4.20		
120	2.15	4.20		
180	2.67	4.20		
190	2.76	4.20		
270	3.46	4.20		
360	4.24	4.74		
370	4.33	4.83		
540	5.81	6.31		
550	5.90	6.40		
720	7.38	7.88		
730	7.47	7.97	.06	.13

RATINGS

Torque Factor: in. lb./p.s.i.		.077
Max. Working Pressure, p.s.i.:	Air	105
	Oil	105
Max. Torque: Non-shock, in. lb.		8
Max. Thrust: Non-shock, lb.		8
Max. Radial Load: Non-shock, lb.		8
Displacement: in ³ /deg.		.0013
Weight 180 std. unit: lb.		0.5



NOTES:
1. Switch mounts by strap to cylinder; place as required for access and signal phasing; R (Sink) or S (Source) switches only.

A1 & A12 ROTARY ACTUATORS

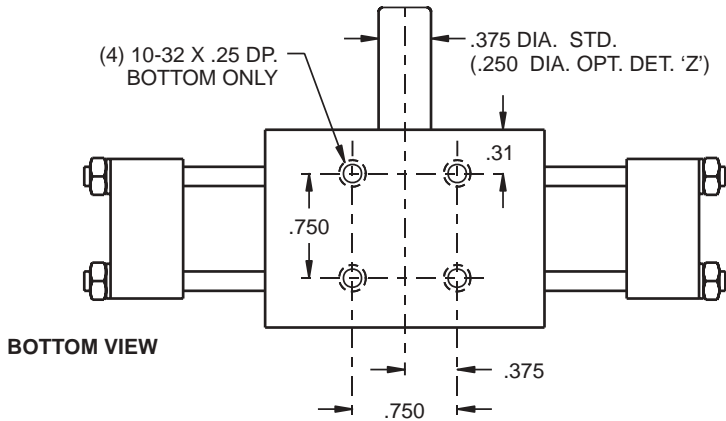
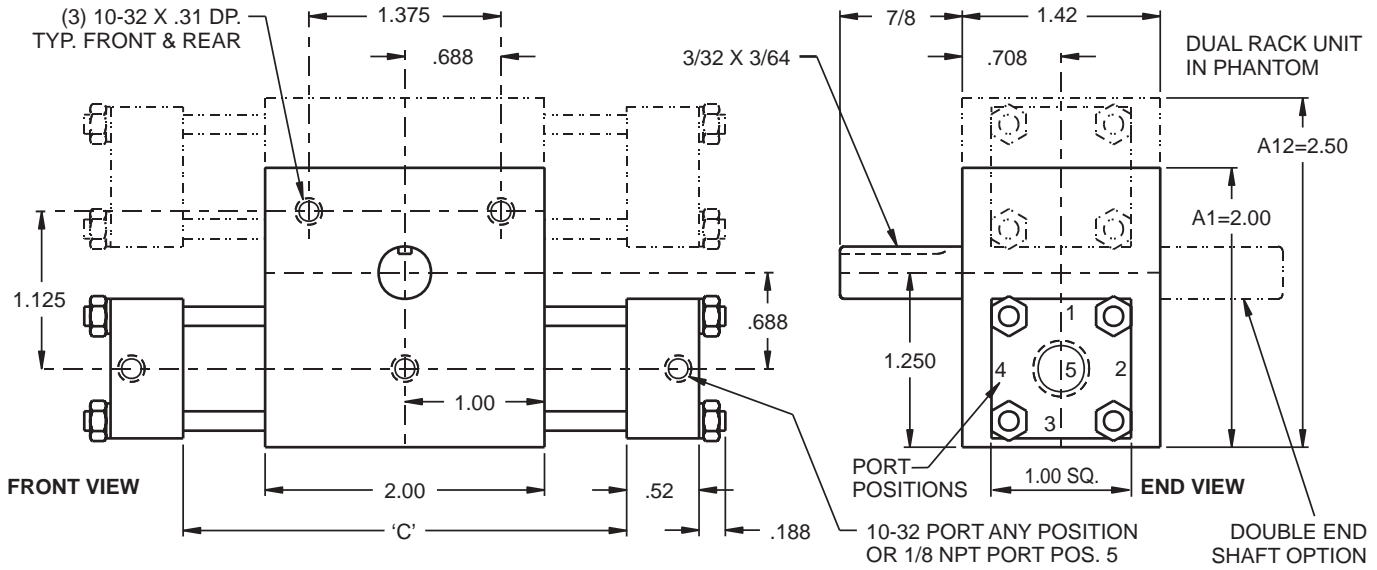

'C' & 'F' NEEDLE VALVE SPECIFY POS. 1, 2, 3 OR 4

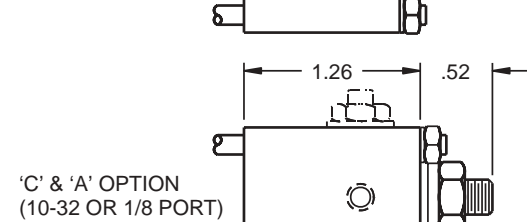
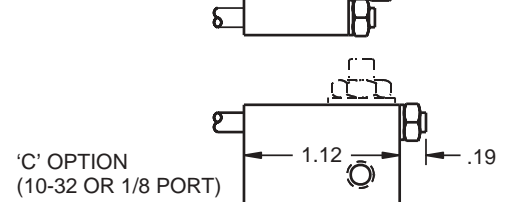
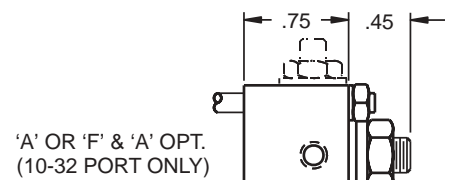
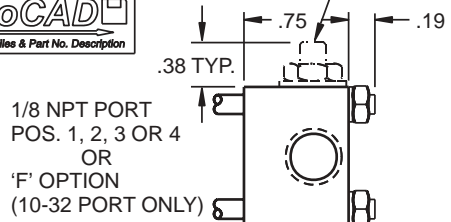

ROTATION	'C' DIMENSION				ADD TO 'C' DIM. PER SIDE	
	A1		A12		'Q' OPTION	'Q' & 'A' OPT.
30 DEG.	2.06	4.95	2.65	5.02	.06	.13
45	2.06	5.08	2.91	5.15		
60	2.28	5.21	3.18	5.28		
90	2.81	5.21	3.70	5.28		
100	2.98	5.21	3.87	5.28		
120	3.33	5.21	4.22	5.28		
180	4.38	5.21	5.27	5.77		
190	4.55	5.21	5.45	5.95		
270	5.95	6.45	6.84	7.34		
360	7.52	8.02	8.41	8.91		
370	7.69	8.19	8.59	9.09		
540	10.66	11.16	11.55	12.05		
550	10.83	11.33	11.73	12.23		
720	13.80	14.30	14.70	15.20		
730	13.98	14.48	14.87	15.37	.06	.13

RATINGS		A1	A12
Torque Factor: in. lb./p.s.i.		.153	.306
Max. Working Pressure, p.s.i.:	Air	150	150
	Oil	300	300
Max. Thrust: Non-shock, lb.		40	40
Max. Radial Load: Non-shock, lb.		40	40
Displacement: in ³ /deg.		.0026	.0052
Weight 180 std. unit: lb.		1.0	1.6

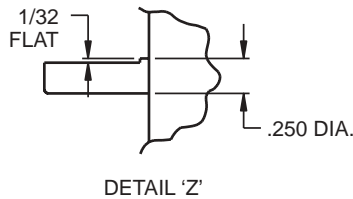

NOTES:
1. Switch mounts by strap to cylinder; place as required for access and signal phasing; R (Sink) or S (Source) switches only.



BUILT FOR OEM - RIGHT MOTION - RIGHT SIZE

DO IT IN THREES



The "LOCK STEP ACTUATOR" drives three shafts in spooky synchronism. A42-360 triple shown.

DOUBLE TORQUE - FIVE POSITIONS



A44-90/45-0-90/45-HS75-1/4-1,3 SHOWN

SAVE SPACE WITH HYBRID STEPPING ACTUATOR



Cramped for space (note necked down tie rods) but need lots of torque In washdown package. S3 drive cylinder, S2 reset cylinder. Symbol: written description

CAPABLE AND TOUGH



Three position A12: exposed parts electroless nickel plated or solid stainless steel.

CONCENTRIC SHAFT ACTUATORS



Two actuators on same centerline. Concentric shafts independently driven. A2 and A4 shown.

DOUBLE TORQUE, DOUBLE UNITS



High torque in small package. Symbol: 44 S44-360-CW-S10-3C2-1/4-1,3 shown A special that has become popular.

THREE POSITIONS-GENTLY



Moves fragile product to any of three positions. Smooth motion, progressive cushions with fine adjustment, shaft to fit load. A22 shown.

OEM SPECIALS

With just a few custom parts, units uniquely suited to process functions provide low cost means to efficient, reliable productions systems.

DESIGN YOUR 1" TO 2" BORE TIE ROD ROTARY ACTUATOR

BORE RACKS SERIES SYMBOL		MOTION SYMBOL		OPTION			ROTATION DIRECTION CONTROLLED			NEEDLE VALVE POSITION	
BORE	RACKS	TOP CENTERED	CLOCKWISE	FLOW CONTROL	CUSHION	BUMPER	CW	CCW	BOTH		
1	1	TC	CW	1F	1C	1Q	1F	1C	1Q	1,2,3 or 4	
1	2			2F	2C	2Q	2F	2C	2Q	1,2,3 or 4	
1 3/8	1			3F	3C	3Q	3F	3C	3Q	1,2,3 or 4	
1 3/8	2										
2	1										
2	2										

OPTION	ROTATION DIRECTION CONTROLLED	NEEDLE VALVE POSITION
FLOW CONTROL	1F 2F 3F	1,2,3 or 4
CUSHION	1C 2C 3C	1,2,3 or 4
BUMPER	1Q 2Q 3Q	
ADJUSTABLE ROTATION	1A 2A 3A	
SEALS, NITRILE (STD.)	-	
SEALS, FLUOROCARBON	V	
SEALS, PRETENSIONED	T	
SEALS, FLUOROCARBON PRETENSIONED	VT	

SERIES	SYMBOL	PLATE SYMBOL
A2,A22	1/8 NPT	BOTTOM M
A3,A32	1/4 NPT	FRONT N
A4,A42	1/4 NPT	REAR P

OTHER SIZES TO ORDER

SEE CATALOG PAGE 42

SERIES A22 **BORE** 100 **MOTION** TC **SHAFT KEYWAY** S5KK **ROTATION** 1F1 **CUSHION** 2C1 **BUMPER** 1Q **ADJUSTABLE** 2A **SEALS** 2SL **SEALS** V **PORT SIZE** 1/8 **PORT POSITION** 2 **MOUNT PLATES** N

OPTIONAL ANGLES:	SERIES	STANDARD	OPTION SYMBOL
30, 45, 60, 90, 100, 120, 180, 190, 270, 360, 370, 540, 550, 720, 730, OR AS SPECIFIED	A2, A22	S5	D5, HS37
	A3, A32	S75	D75, HS75
	A4, A42	S10 or S11*	D10, D11, HS75

SYMBOL	INDICATES	OUTPUT CIRCUIT	LEAD
1	CW	R NPN Sink	L 9' Lead
2	CCW	S PNP Source	C Connector
3	BOTH	N No Switch	
		Mag Only	
4	4 Switches for 3 Position Actuator		
5	6 Switches for 4 Position Actuator		
6	8 Switches for 5 Position Actuator		

See Mag. Switches, Catalog Pg. 40, 41 & Multi-Position, Catalog Pg. 39

EXTENSION CABLES FOR SWITCHES WITH PIGTAIL AND CONNECTOR

ORDER SEPARATELY	
CABLE	PART NUMBER
2 METER LENGTH	CC2
5 METER LENGTH	CC5

SEAL REPAIR KITS

PART NUMBERS FOR SEAL REPAIR KITS

FILL IN UNIT SERIES AND ALL RELATED OPTIONS:

SRK - [A22] [90-0-90] [F] [C] [A] [V]

SERIES ANGLES/POSITION FLOW CUSHIONS ROTATION SEALS
IF MULTI-POSITION CONTROL ADJUSTERS

EXAMPLES:
SEAL KIT FOR A32-45-0-45-S75-3C3-1/4-2 = SRK-A32-45-0-45-C
NOTE: IF NO OPTIONS, SPECIFY SRK-A32-STD.

When an option is not required, leave blank.

Write out any special requirements in English or provide a dimensioned sketch. Rotomation can provide units to almost any configuration.

To expedite the order of a duplicate of a prior unit, refer to prior invoice/serial number stamped on the unit body.

Needle valve cannot be on same side as port.

OPTIONAL ANGLES:
30, 45, 60, 90, 100, 120, 180, 190, 270, 360, 370, 540, 550, 720, 730, OR AS SPECIFIED

MULTI-POSITION A22, A32 & A42:
3 POS: A-P-B
4 POS: A-P-B/C or A/B-P-C
5 POS: A/B-P-C/D
SEE CATALOG PAGE 39

PRELOADED KEYWAY: KK
DIMENSIONS: SEE CATALOG PAGE 43
SPECIALS: SEND SKETCH
* NO COST

S=SINGLE END 5=500 DIA.
D=DOUBLE END 75=750 DIA.
HS=HOLLOW SHAFT 10=1.000 DIA.
R=REAR PROJECTION 11=1.125 DIA.

NOTE: PORT CANNOT BE ON SAME SIDE AS NEEDLE VALVE. PORT LOCATION 5 NOT AVAILABLE WITH A, C OR F OPTION.

CALCULATED TORQUE IN INCH-POUNDS
Deduct 10% for friction

UNIT	OPERATING PRESSURE IN PSI						
	25	50	60	80	100	200	300 (HP)
A2	12.2	24.5	29.4	39.2	49	98	147
A22	24.5	49	58.8	78.4	98	196	294
A3	37.2	74.5	89.4	119	149	298	447
A32	74.5	149	179	238	298	596	894
A4	86.5	173	208	277	346	692	1038
A42	173	346	415	554	692	1384	2076

High pressure option (HP) should be used for pressures exceeding 250 psi.

LOCATING DOWEL PIN SOCKETS-TIE ROD UNITS

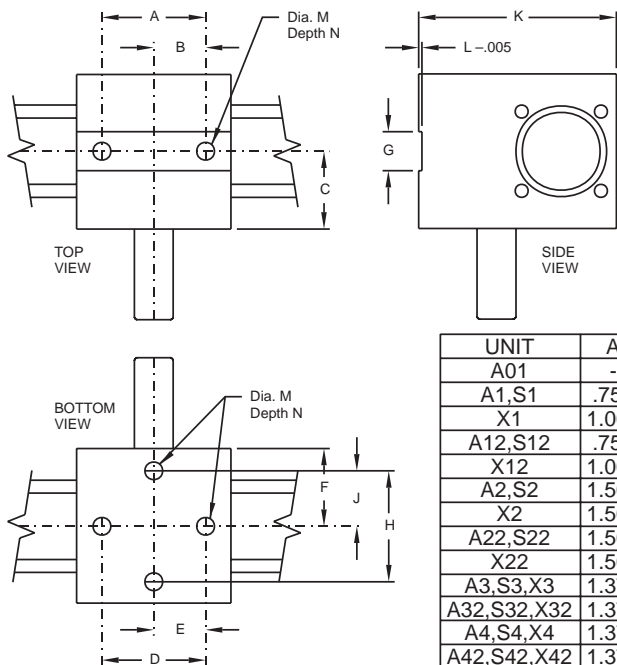

Initial and replacement unit installations can be made precisely using locating dowel pin sockets in Rotomation units.

Socket locations and dimensions are listed below for tie rod units. Note that sockets on unit top are in machine finished groove under Rotomation label.

UNIT	A	B	C	D	E	F	G	H	J	K	L	M	N
A01	-	-	-	.750	.375	.50	-	-	-	1.50	-	.125	.090
A1,S1	.750	.375	.708	.750	.375	.708	-	-	-	1.50	-	.188	.150
X1	1.000	.500	1.311	1.000	.500	1.311	-	-	-	2.00	-	.188	.150
A12,S12	.750	.375	.708	.750	.375	.708	-	-	-	2.50	-	.188	.150
X12	1.000	.500	1.311	1.000	.500	1.311	-	-	-	2.50	-	.188	.150
A2,S2	1.500	.750	.991	-	-	-	.750	1.500	.750	2.69	.030	.250	.200
X2	1.500	.750	1.500	1.500	.750	1.500	.750	-	-	2.69	.030	.250	.200
A22,S22	1.500	.750	.991	-	-	-	.750	1.500	.750	3.38	.030	.250	.200
X22	1.500	.750	1.500	1.500	.750	1.500	.750	-	-	3.38	.030	.250	.200
A3,S3,X3	1.375	.6875	1.490	1.563	.781	1.490	.750	-	-	3.81	.030	.375	.250
A32,S32,X32	1.375	.6875	1.490	1.563	.781	1.490	.750	-	-	4.63	.030	.375	.250
A4,S4,X4	1.375	.6875	1.490	2.000	1.000	1.490	.750	-	-	4.31	.030	.375	.250
A42,S42,X42	1.375	.6875	1.490	2.000	1.000	1.490	.750	-	-	5.50	.030	.375	.250

A2 & A22 ROTARY ACTUATORS

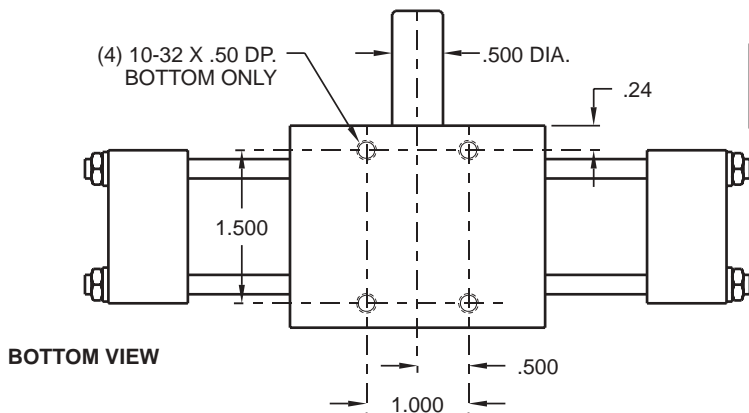
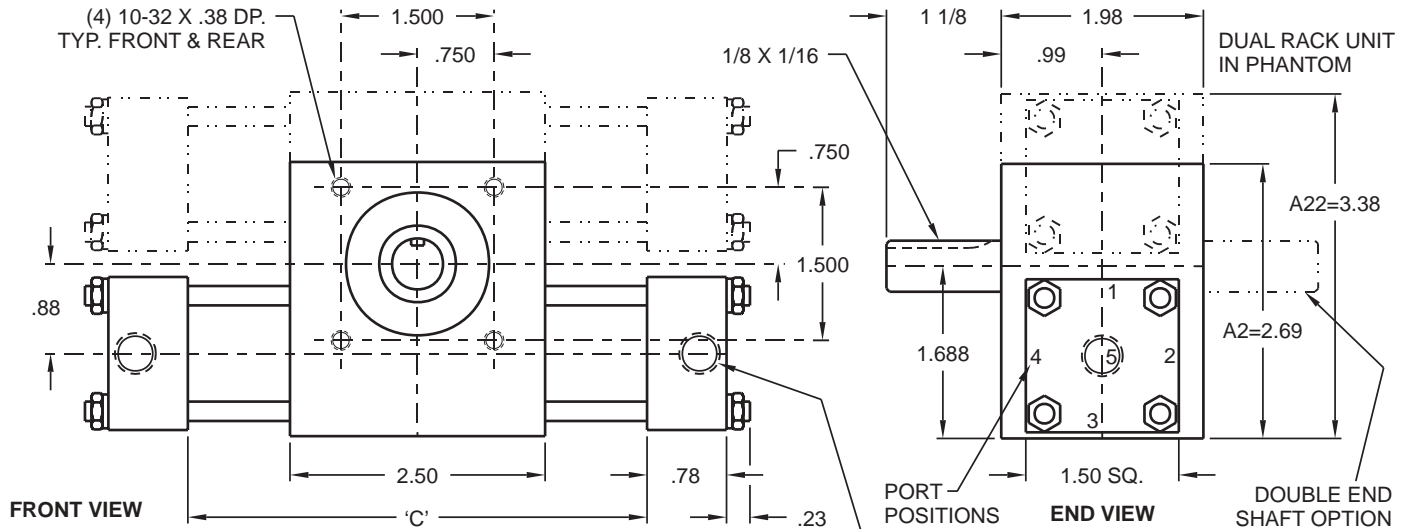

'C' OR 'F' NEEDLE VALVE SPECIFY POS. 1, 2, 3 OR 4

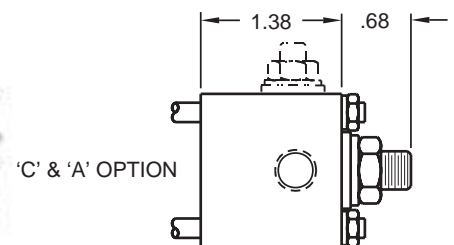
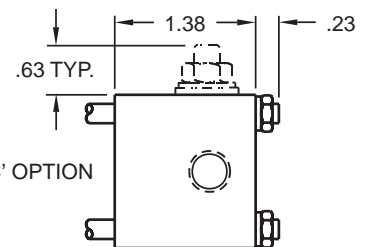
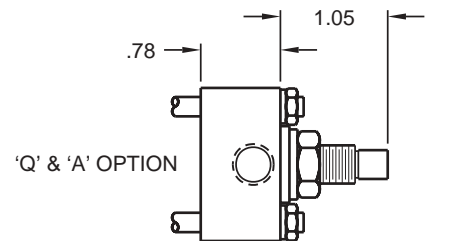
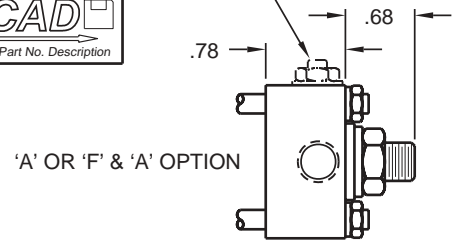

ROTATION	'C' DIMENSION				ADD TO 'C' DIM. PER SIDE		
	A2		A22		'Q' OPT.	'Q' & 'A' OPT.	'HP' OPT.
	STD.	'G', 'R' OR 'S' OPT.	STD.	'G', 'R' OR 'S' OPT.			
30 DEG.	3.30	6.05	3.36	6.12	.06	.22	.50
45	3.62	6.22	3.68	6.29			
60	3.95	6.38	4.01	6.45			
90	4.60	6.38	4.66	6.45			
100	4.82	6.38	4.88	6.45			
120	5.26	6.38	5.32	6.45			
180	6.57	7.57	6.63	7.63			
190	6.79	7.79	6.85	7.85			
270	8.53	9.53	8.59	9.59			
360	10.50	11.50	10.56	11.56			
370	10.71	11.71	10.77	11.77			
540	14.42	15.42	14.48	15.48			
550	14.64	15.64	14.70	15.70			
720	18.35	19.35	18.41	19.41			
730	18.57	19.57	18.63	19.63	.06	.22	.50

RATINGS		A2	A22
Torque Factor: in. lb./p.s.i.		.49	.98
Max. Working Pressure, p.s.i.:	Air	250	250
	Oil	750	750
Max. Thrust: Non-shock, lb.		100	100
Max. Radial Load: Non-shock, lb.		85	85
Displacement: in ³ /deg.		.0086	.0172
Weight 180 std. unit: lb.		2.3	3.6

NOTES:

- For oil pressures exceeding approximately 250 psi recommend option HP which adds 1" to 'C' dimension.
- Switch bracket mounts to tie rod; place as required for access and signal phasing.



A3 & A32 ROTARY ACTUATORS

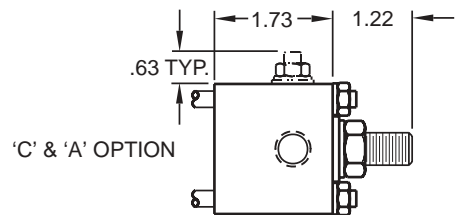
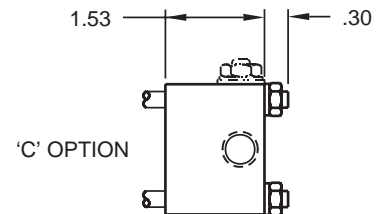
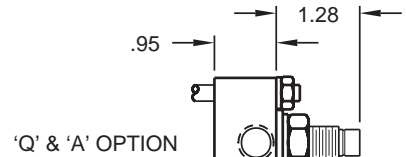
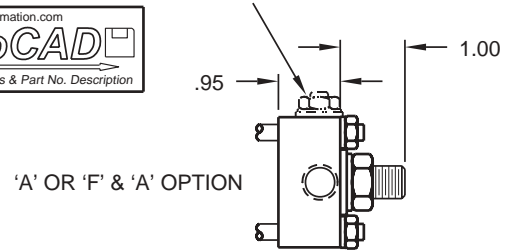
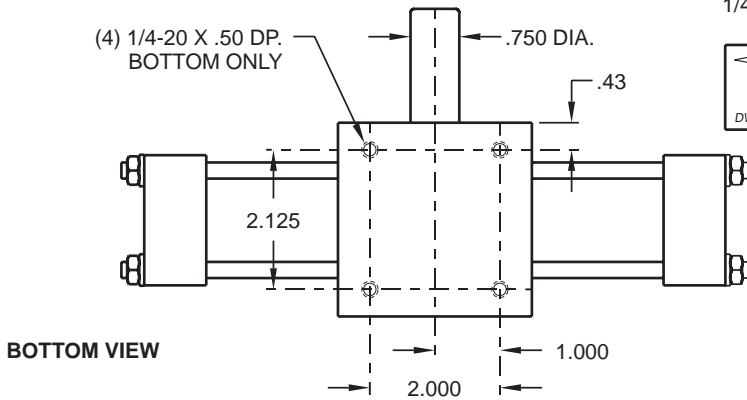
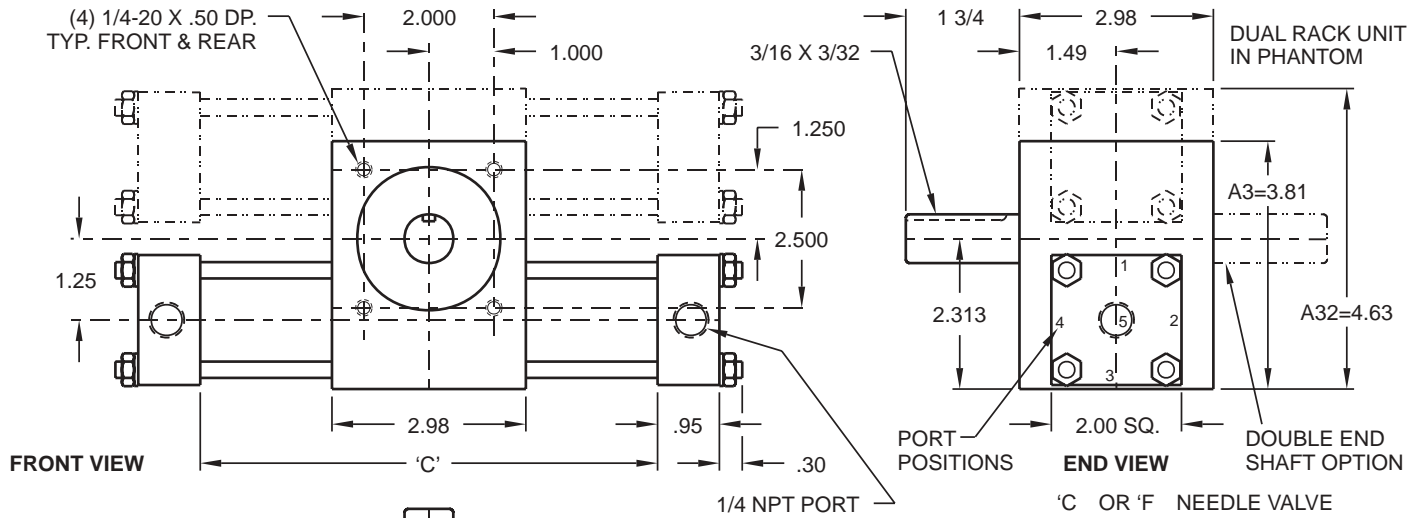

ROTATION	'C' DIMENSION				ADD TO 'C' DIM. PER SIDE		
	A3		A32		'Q' OPT.	'Q' & 'A' OPT.	'HP' OPT.
	STD.	'G', 'R' OR 'S' OPT.	STD.	'G', 'R' OR 'S' OPT.			
30 DEG.	4.44	6.63	4.50	6.70	.06	.29	.50
45	4.96	6.90	5.02	6.97			
60	5.49	7.16	5.55	7.23			
90	6.53	7.53	6.59	7.59			
100	6.88	7.88	6.94	7.94			
120	7.58	8.58	7.64	8.64			
180	9.68	10.68	9.74	10.74			
190	10.03	11.03	10.09	11.09			
270	12.82	13.82	12.88	13.88			
360	15.96	16.96	16.02	17.02			
370	16.31	17.31	16.37	17.37			
540	22.24	23.24	22.30	23.30			
550	22.59	23.59	22.65	23.65			
720	28.53	29.53	28.59	29.59			
730	28.87	29.87	28.93	29.93	.06	.29	.50

RATINGS		A3	A32
Torque Factor: in. lb./p.s.i.		1.49	2.98
Max. Working Pressure, p.s.i.:	Air	250	250
	Oil	750	750
Max. Thrust: Non-shock, lb.		300	300
Max. Radial Load: Non-shock, lb.		300	300
Displacement: in ³ /deg.		.026	.052
Weight 180 std. unit: lb.		6.1	8.8

- NOTES:
- For oil pressures exceeding approximately 250 psi recommend option HP which adds 1" to 'C' dimension.
 - Switch mounts by strap to cylinder; place as required for access and signal phasing.



A4 & A42 ROTARY ACTUATORS

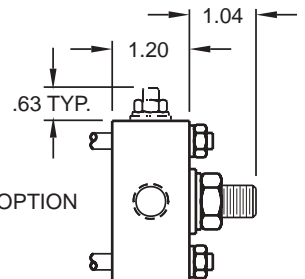
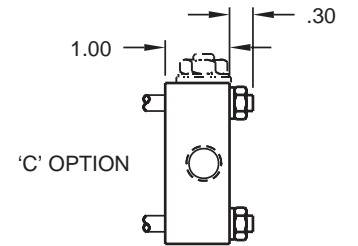
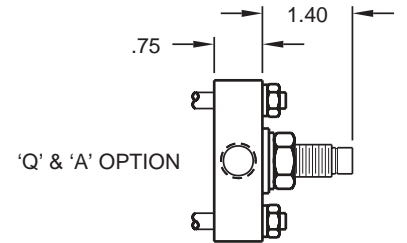
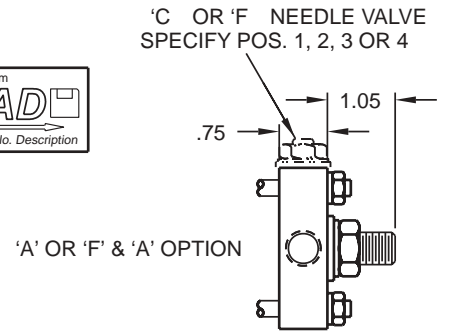
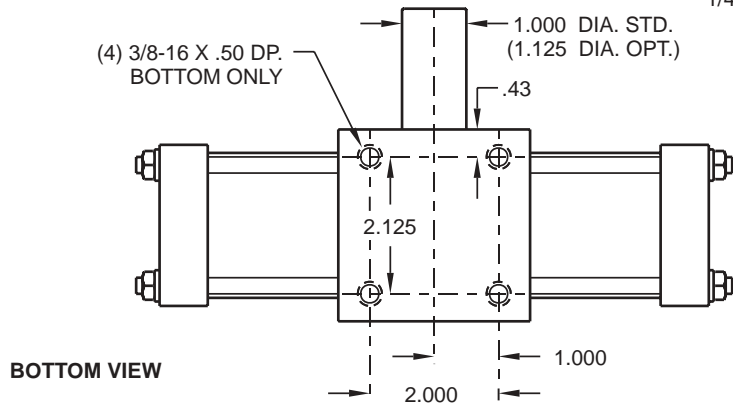
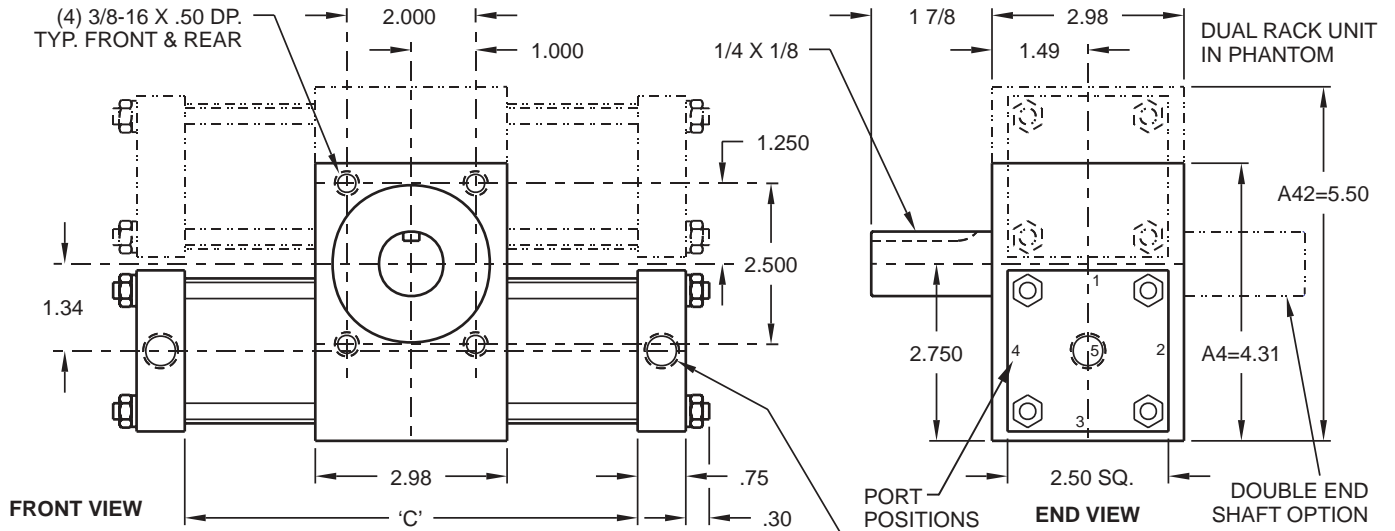

ROTATION	'C' DIMENSION				ADD TO 'C' DIM. PER SIDE		
	A4		A42		'Q' OPT.	'Q' & 'A' OPT.	'HP' OPT.
	STD.	'G', 'R' OR 'S' OPT.	STD.	'G', 'R' OR 'S' OPT.			
30 DEG.	6.81	7.29	6.87	7.36	.06	.29	1.00
45	7.39	7.58	7.45	7.65			
60	7.96	7.96	8.02	8.02			
90	9.12	9.12	9.18	9.18			
100	9.50	9.50	9.56	9.56			
120	10.27	10.27	10.33	10.33			
180	12.57	12.57	12.63	12.63			
190	12.95	12.95	13.01	13.01			
270	16.03	16.03	16.09	16.09			
360	19.48	19.48	19.54	19.54			
370	19.87	19.87	19.93	19.93			
540	26.39	26.39	26.45	26.45			
550	26.78	26.78	26.84	26.84			
720	33.31	33.31	33.37	33.37			
730	33.69	33.69	33.75	33.75	.06	.29	1.00

RATINGS		A4	A42
Torque Factor: in. lb./p.s.i.:		3.46	6.92
Max. Working Pressure, p.s.i.:	Air	250	250
	Oil	750	750
Max. Thrust: Non-shock, lb.		300	300
Max. Radial Load: Non-shock, lb.		300	300
Displacement: in ³ /deg.		.060	.121
Weight 180 std. unit: lb.		9.3	14.3



- NOTES:
- For oil pressures exceeding approximately 250 psi recommend option HP which adds 2" to 'C' dimension.
 - Switch bracket mounts to tie rod; place as required for access and signal phasing.



ONE STEP AT A TIME: THE INDEXING ACTUATOR



BODY: HEAT TREATED ALUMINUM ALLOY, ANODIZED, TAPPED MOUNT HOLES ON FRONT AND BOTTOM, ON REAR ALSO IN X1, X12, X2 AND X22

GEAR: HEAT TREATED ALLOY STEEL, INTERNAL CLUTCH BEARING

CLUTCH BEARING: VERY HIGH RADIAL LOAD

SHAFT: HARDENED AND TEMPERED TOOL STEEL

REPLACEABLE RACK BEARINGS OF OIL IMPREGNATED BRONZE IN X2 AND LARGER UNITS. X1 AND X12 HAVE CAPTIVE PISTON-BEARINGS.

LUBRICATION: LITHIUM BASED GREASE WITH PTFE. SEE INSTALLATION AND MAINTENANCE INSTRUCTIONS.

BALL BEARING: SEALED, HIGH RADIAL AND THRUST CAPABILITY

RATCHET: PRECISELY CUT OF 4150 (125,000 PSI MIN.) STEEL

EXTENDED PAWL SHAFT (OPTION), ROTATES 7 DEG. AT INDEX AND BACK 7 DEG. AT RESET; CAN BE USED FOR SIGNAL

PAWL: HARDENED STEEL

SPRING: HARDENED SPRING WIRE

CAM: HARDENED STEEL

CYLINDER: HARD ANODIZED ALUMINUM. X2 AND LARGER UNITS: OPTIONAL STEEL, CHROME PLATED HONED I.D. AND EPOXY COATED O.D.

PISTON: CORROSION RESISTANT ALUMINUM ALLOY, FLOATING IN X2 AND LARGER UNITS. CAN BE EQUIPPED WITH MAGNET. X1 AND X12 HAVE CAPTIVE PISTON.

PISTON SEAL: PRESSURE ENERGIZED, LOW BREAKAWAY, NITRILE, FKM OR OTHER AS REQUIRED.

END CAPS: ANODIZED, HEAT TREATED ALUMINUM ALLOY. O-RING SEALS, METAL TO METAL CONTACT WITH CYLINDER.



CONSTRUCTION AND OPERATION

Construction and external size similar to rack and pinion actuator, but pinion drives shaft one way through overrunning clutch.

Four way valve controls full cycle

Drive: Rack drives pinion, pinion drives shaft through overrunning clutch until pawl stops and locks ratchet.

Lock: Pawl prevents forward motion, rack force and non-return clutch prevent reverse motion.

Reset: Rack reverses, drives pinion backward to start point, cam lifts pawl; shaft remains stationary held by non-return clutch.

Each shaft step controlled by accurately cut ratchet.

Sensors and system signals

Extended pawl shaft moves 7 deg. at index and reset; use proximity detector, low force sensitive switch or pilot valve
Magnetic pistons and switches

Shaft Motion

Angular step accuracy: 0.2 degree

No cumulative error

Shaft locked in both directions in index position at end of drive stroke

Stop at end of drive stroke is abrupt; avoid shock by flow control of exhausting cylinder to limit velocity

Drive is through overrunning clutch; cushion on drive cylinder ineffective without friction in load

Shaft movable in forward direction by outside torque in reset

No reverse shaft motion: Non-return clutch

Reset operation quick, moves only pistons, rack, pinion, cam pawl.

Silence with cushion if desired.

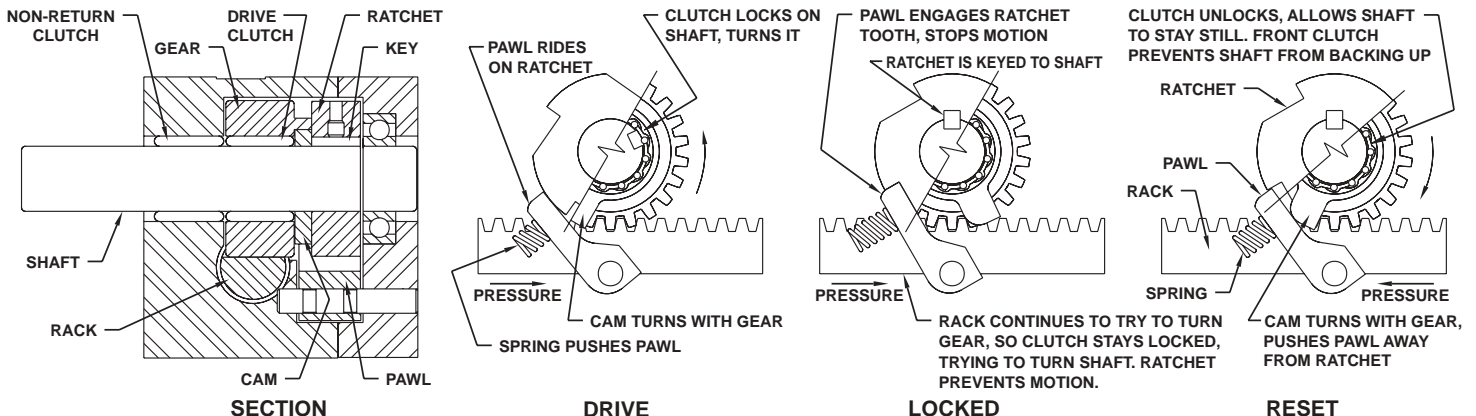

APPLICATIONS-POSSIBLE ONLY WITH ROTOMATION INDEXING ACTUATORS

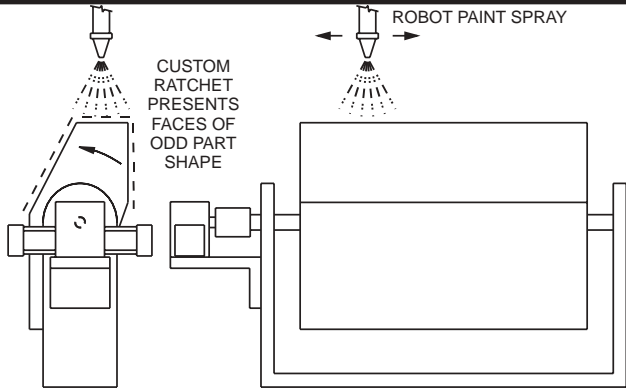

INDEXING SPRAY SYSTEM

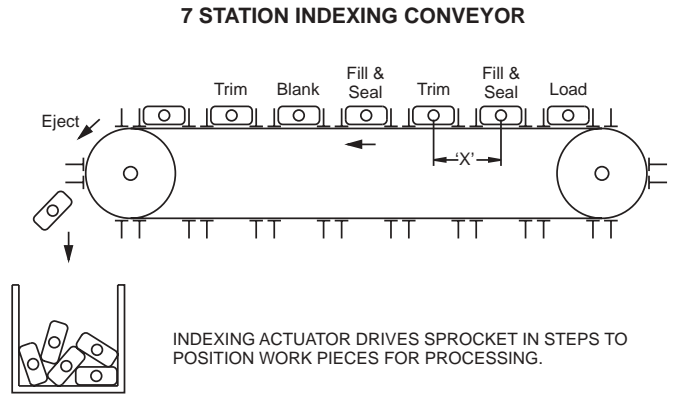

7 STATION INDEXING CONVEYOR
INDEXING ACTUATOR DRIVES SPROCKET IN STEPS TO POSITION WORK PIECES FOR PROCESSING.

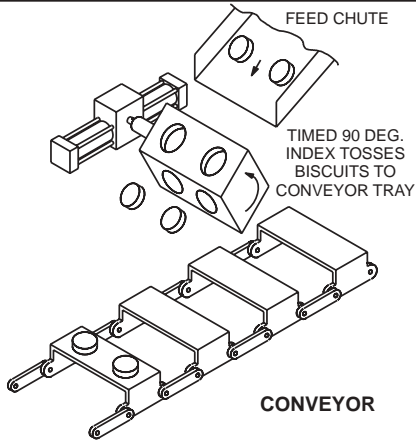

CONVEYOR

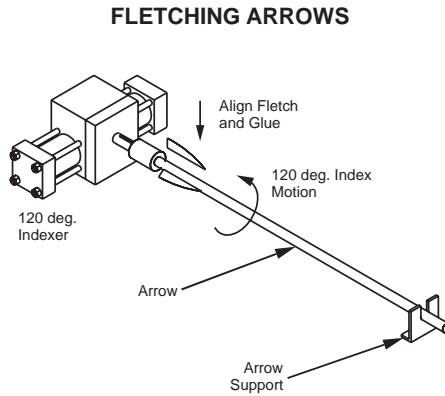

FLETCHING ARROWS

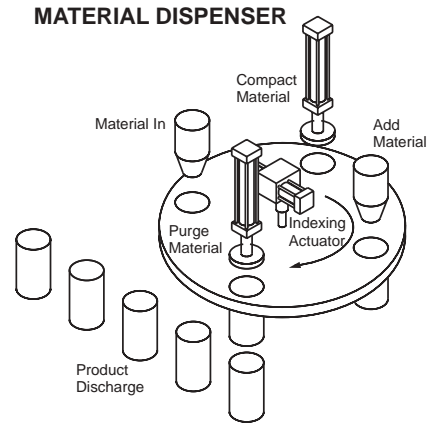

MATERIAL DISPENSER

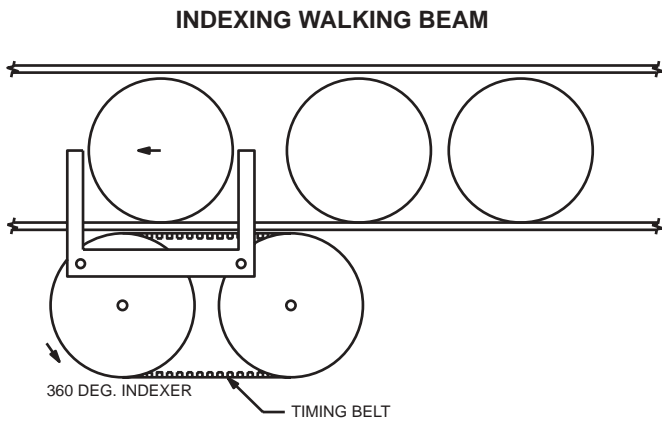

INDEXING WALKING BEAM

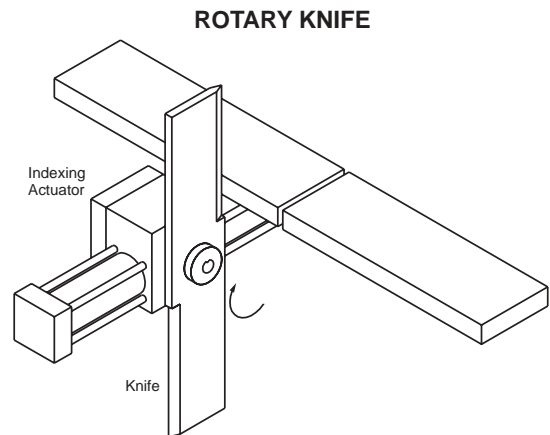

ROTARY KNIFE



TESTING USING MULTIPLE REAGENTS

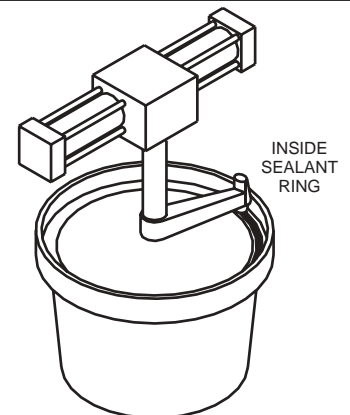
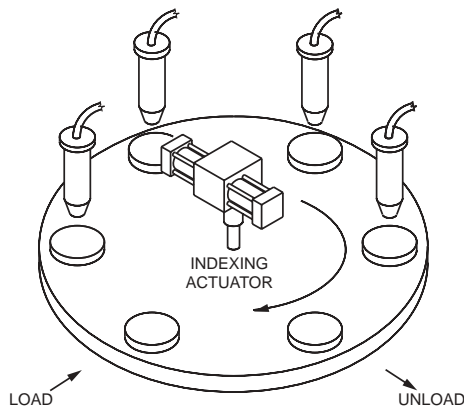

DISPENSE ADHESIVE



DESIGN YOUR INDEXING ACTUATOR

SIZE & CONTROLS LIKE CONVENTIONAL ROTARY ACTUATOR



When an option is not required, leave blank.

Write out any special requirements in English or provide a dimensioned sketch. Rotomation can provide units to almost any configuration.

To expedite the order of a duplicate of a prior unit, refer to prior invoice/serial number stamped on the unit body.

BORE	RACKS	SERIES SYMBOL
5/8	1	X1
5/8	2	X12
1	1	X2
1	2	X22
1 3/8	1	X3
1 3/8	2	X32
2	1	X4
2	2	X42

ROTATION SYMBOL	
CLOCKWISE	CW
COUNTER CLOCKWISE	CCW
NO COST	

OPTION	OPERATION CONTROLLED			NEEDLE VALVE POSITION
	DRIVE	RESET	BOTH	
FLOW CONTROL	1F	2F	3F	1,2,3 or 4
CUSHION	1C	2C	3C	1,2,3 or 4
BUMPER	-	2Q	-	
SEALS, NITRILE (STD.)	-	V		
SEALS, FLUOROCARBON	-	T		
SEALS, PRETENSIONED	-	VT		
SEALS, FLUOROCARBON PRETENSIONED	-	VT		

SERIES	SYMBOL
X1,X12	10.32*
X2,X22	1/8 NPT
X3,X32	1/4 NPT
X4,X42	1/4 NPT

*1/8 NPT OPTIONAL, NO COST
OTHER SIZES TO ORDER

PLATE	SYMBOL
BOTTOM	M
FRONT	N
REAR	P
X1, X12, X2, X22	BP
X3, X32, X4, X42	

SPECIFY BP FOR REAR MOUNT CONSTRUCTION AND MOUNT PLATE OPPOSITE SHAFT.
SEE PAGE 42

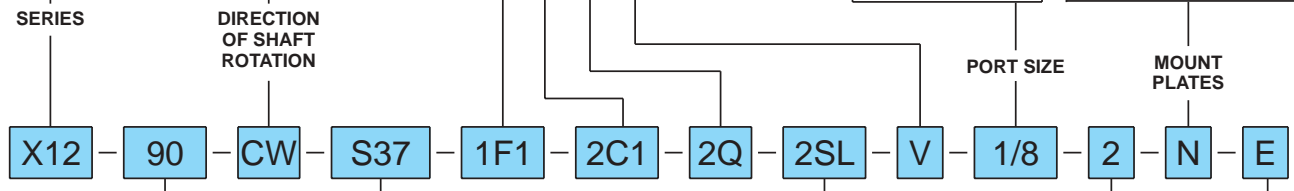

OPTIONAL ANGLES:
12, 15, 18, 22.5, 30, 36, 45, 60, 72, 90, 120, 180, 360 OR COMBINATION

SERIES	STANDARD	OPTION SYMBOL
X1,X12	S37	D37
X2,X22	S5	D5
X3,X32	S75	D75
X4,X42	S10	D10

DIMENSIONS: SEE PAGE 43

S=SINGLE END 37=.375 DIA.
D=DOUBLE END 5=.500 DIA.
75=.750 DIA.
10=1.000 DIA.

POSITION	CONTROLS	OUTPUT CIRCUIT	LEAD
1	DRIVE	R NPN Sink	L 9' Lead
2	RESET	S PNP Source	C Connector
3	BOTH	G Reed	
		N No Switch	
			Mag Only

NOTE: REED SWITCH 'G' NOT AVAILABLE ON X1, X12. SEE PAGE 40, 41

SERIES	SYMBOL
ALL	1,2,3,4,5
NO COST	

NOTE: PORT CANNOT BE ON SAME SIDE AS NEEDLE VALVE

EXTENDED PAWL SHAFT	SYMBOL
KEYWAY LOCATION	KL
HEAVY DUTY	A or K
REAR MOUNT CONSTRUCTION (NO PLATE)	B

EXTENSION CABLES FOR SWITCHES WITH PIGTAIL AND CONNECTOR

ORDER SEPARATELY	
CABLE	PART NUMBER
2 METER LENGTH	CC2
5 METER LENGTH	CC5

SEAL REPAIR KITS

PART NUMBERS FOR SEAL REPAIR KITS
FILL IN UNIT SERIES AND ALL RELATED OPTIONS:

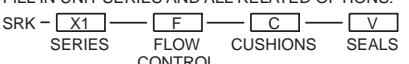

EXAMPLES:
SEAL KIT FOR X3-90-CCW-S75-3F2-1/4-1 = SRK-X3-F

NOTE: IF NO OPTIONS, SPECIFY SRK-X3-STD.



CALCULATED TORQUE IN INCH-POUNDS

Deduct 10% for friction

UNIT	OPERATING PRESSURE IN PSI					
	25	50	60	80	100	200
X1	3.8	7.6	9.2	12.3	15.3	30.7
X12	7.6	15.2	18.4	24.6	30.6	-
X2	12.2	24.5	29.4	39.2	49	-
X22	24.5	49	58.8	-	-	-
X3	37.2	74.5	89.4	119	149	-
X32	74.5	149	-	-	-	-
X4	86.5	173	208	277	346	-
X42	173	346	415	-	-	-

INDEX SIGNALING - EXTENDED PAWL SHAFT

Mechanical signal of index and reset. Sense with switch, pilot valve or proximity detector.

Pawl and shaft move 7/16 at index and reset; cam driven at reset, spring driven at index. Use 1" arm, proximity detector or sensitive switch.

Shaft projects 3/4" from back of body. See page 41.

Symbol: E
X3-120-CCW-S75-1F12C1-2E shown.

NOTE that magnetic pistons and switches may also be used on the indexer.

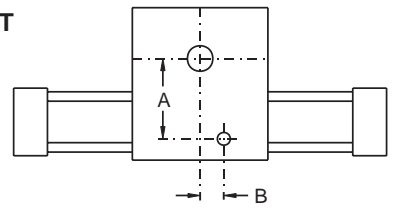

UNIT	SHAFT DIA.	DIM. A	DIM. B	PAWL SHAFT ROTATION	
				DRIVE	RESET
X1 CW	.188	.936	0	CW	CCW
X1 CCW	.188	.936	0	CCW	CW
X2 CW	.250	1.309	+107	CW	CCW
X2 CCW	.250	1.309	-107	CCW	CW
X3 CW	.375	1.875	0	CW	CCW
X3 CCW	.375	1.875	0	CCW	CW
X4 CW	.375	2.201	+188	CW	CCW
X4 CCW	.375	2.201	-188	CCW	CW

+ to right of centerline
- to left of centerline

X1 & X12 INDEXING ACTUATORS

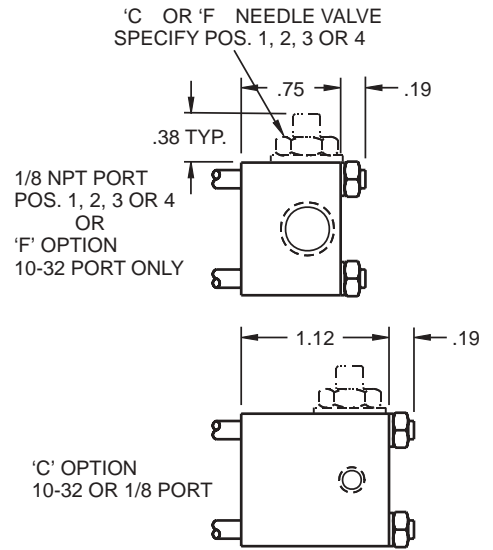
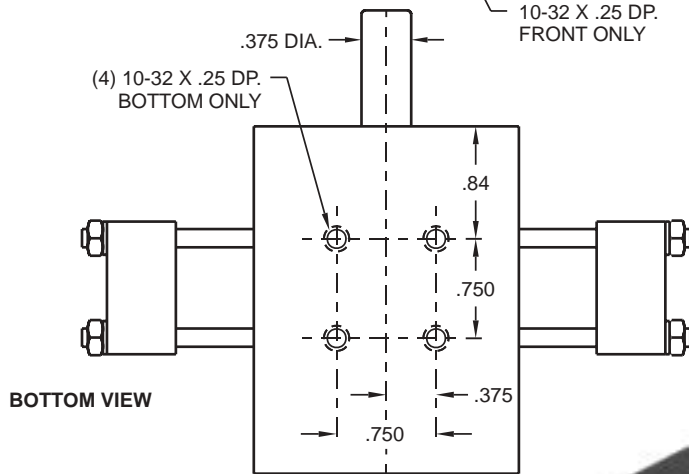
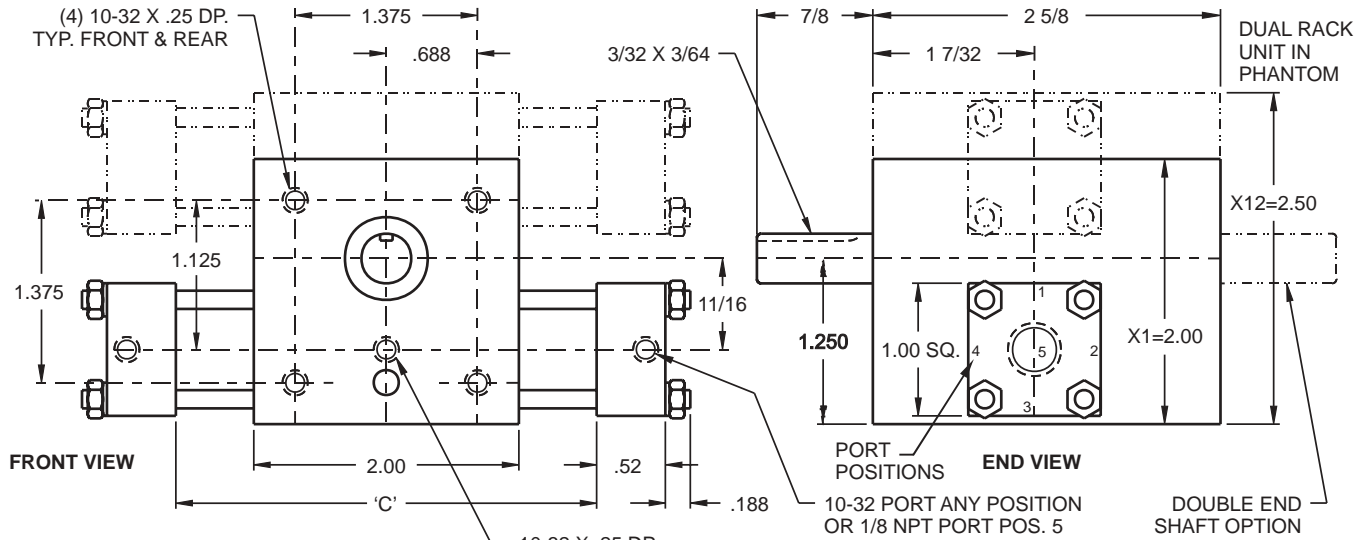

RATINGS

	X1	X12
Torque Factor: in. lb./p.s.i.	.153	.306
Max. Working Pressure, p.s.i.:	Air 150	150
	Oil 300	150
Max. Impact Energy: in. lb.	Front 2.1	2.1
	Rear .4	.4
Max. Torque: Non-shock, in. lb.	45	45
Max. Reverse Torque: Non-shock, in. lb.	23	23
Max. Thrust: Non-shock, lb. *	40	40
Max. Radial Load: Non-shock, lb.	40	40
Displacement: in ³ /deg.	.0026	.0052
Weight 180 std. unit: lb.-oz.	1-11	2-2

* -Thrust inward, front to rear only. Do not apply thrust in opposite direction.

ROTATION	'C' DIMENSION				ADD TO 'C' RESET SIDE
	X1		X12		
	STD.	'R' OR 'S' OPT.	STD.	'R' OR 'S' OPT.	'Q' OPT.
12 DEG.	2.06	4.79	2.06	4.79	.06
15	2.06	4.81	2.06	4.81	
18	2.06	4.84	2.06	4.84	
22.5	2.06	4.88	2.06	4.88	
30	2.06	4.95	2.06	4.95	
36	2.06	5.00	2.06	5.00	
45	2.06	5.08	2.06	5.08	
60	2.31	5.21	2.30	5.21	
72	2.52	5.21	2.51	5.21	
90	2.84	5.21	2.83	5.21	
120	3.36	5.21	3.35	5.21	
180	4.41	5.21	4.40	5.21	
360	7.55	8.05	7.54	8.04	.06

NOTES:

1. An uncontrolled reset stroke can cause some bounce of the rack and a small forward impulse to the shaft. It will be apparent only if the shaft load is small, with low friction. It can be reduced by a bumper (usable on reset cylinder only) or more by a correctly adjusted cushion.
2. Switch mounts by strap to cylinder; place as required for access and signal phasing; R (Sink) or S (Source) switches only.

INDEXING ACCURACY -0.2 deg.

SHAFT KEYWAY POSITION

Reference (start) position of shaft keyway:		
30j indexer	11:30	345j
60j indexer	9:00	270j
120j indexer	6:00	180j
All others	12:00	0j

(Angles measured with respect to bottom of body.)

Accuracy of reference position	-2j
Optional high accuracy reference position (not available on 15, 18 and 22.5 deg. units)	-0.2j

Symbol: KL



X2 & X22 INDEXING ACTUATORS

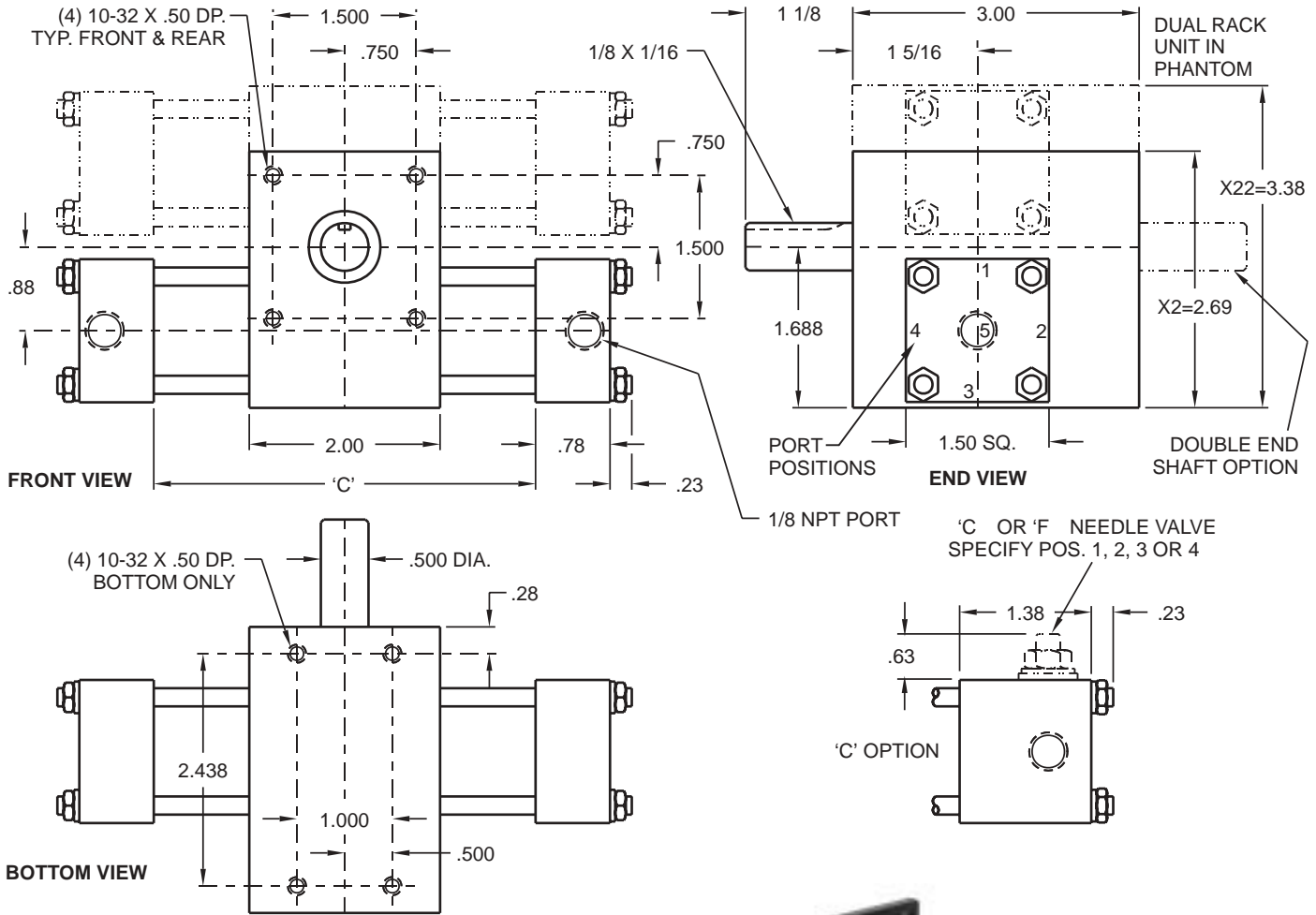

SHOWN WITH OPTIONAL MOUNT PLATE

RATINGS

		X2	X22
Torque Factor: in. lb./p.s.i.		.49	.98
Max. Working Pressure, p.s.i.:	Air	150	75
	Oil	150	75
Max. Impact Energy: in. lb.	Front	4	4
	Rear	1.2	1.2
Max. Torque: Non-shock, in. lb.		73	73
Max. Reverse Torque: Non-shock, in. lb.		37	37
Max. Thrust: Non-shock, lb. ★		50	50
Max. Radial Load: Non-shock, lb.		70	70
Displacement: in. ³ /deg.		.0086	.0172
Weight 180 deg. std. unit: lb.-oz.		2-15	4-8

★ -Thrust inward, front to rear only. Do not apply thrust in opposite direction.

ROTATION	'C' DIMENSION				ADD TO 'C' RESET SIDE
	X2		X22		
	STD.	'G', 'R' OR 'S' OPT.	STD.	'G', 'R' OR 'S' OPT.	'Q' OPT.
12 DEG.	2.90	5.36	2.89	5.36	.06
15	2.97	5.39	2.96	5.39	
18	3.03	5.42	3.02	5.42	
22.5	3.13	5.47	3.12	5.47	
30	3.29	5.55	3.28	5.55	
36	3.43	5.62	3.42	5.62	
45	3.62	5.72	3.61	5.72	
60	3.95	5.88	3.94	5.88	
72	4.21	5.88	4.20	5.88	
90	4.60	5.88	4.59	5.88	
120	5.26	6.26	5.25	6.25	
180	6.57	7.57	6.56	7.56	
360	10.49	11.49	10.48	11.48	.06

NOTES:

- An uncontrolled reset stroke can cause some bounce of the rack and a small forward impulse to the shaft. It will be apparent only if the shaft load is small, with low friction. It can be reduced by a bumper (usable on the reset cylinder only) or more by a correctly adjusted cushion.
- Switch bracket mounts to tie rod; place as required for access and signal phasing.

INDEXING ACCURACY -0.2 deg.

SHAFT KEYWAY POSITION

Reference (start) position of shaft keyway:		
30j indexer	11:30	345j
60j indexer	9:00	270j
120j indexer	6:00	180j
All others	12:00	0j
(Angles measured with respect to bottom of body.)		

Accuracy of reference position -2j
 Optional high accuracy reference position (not available on 15, 18 and 22.5 deg. units) -0.2j
 Symbol: KL



X3 & X32 INDEXING ACTUATORS

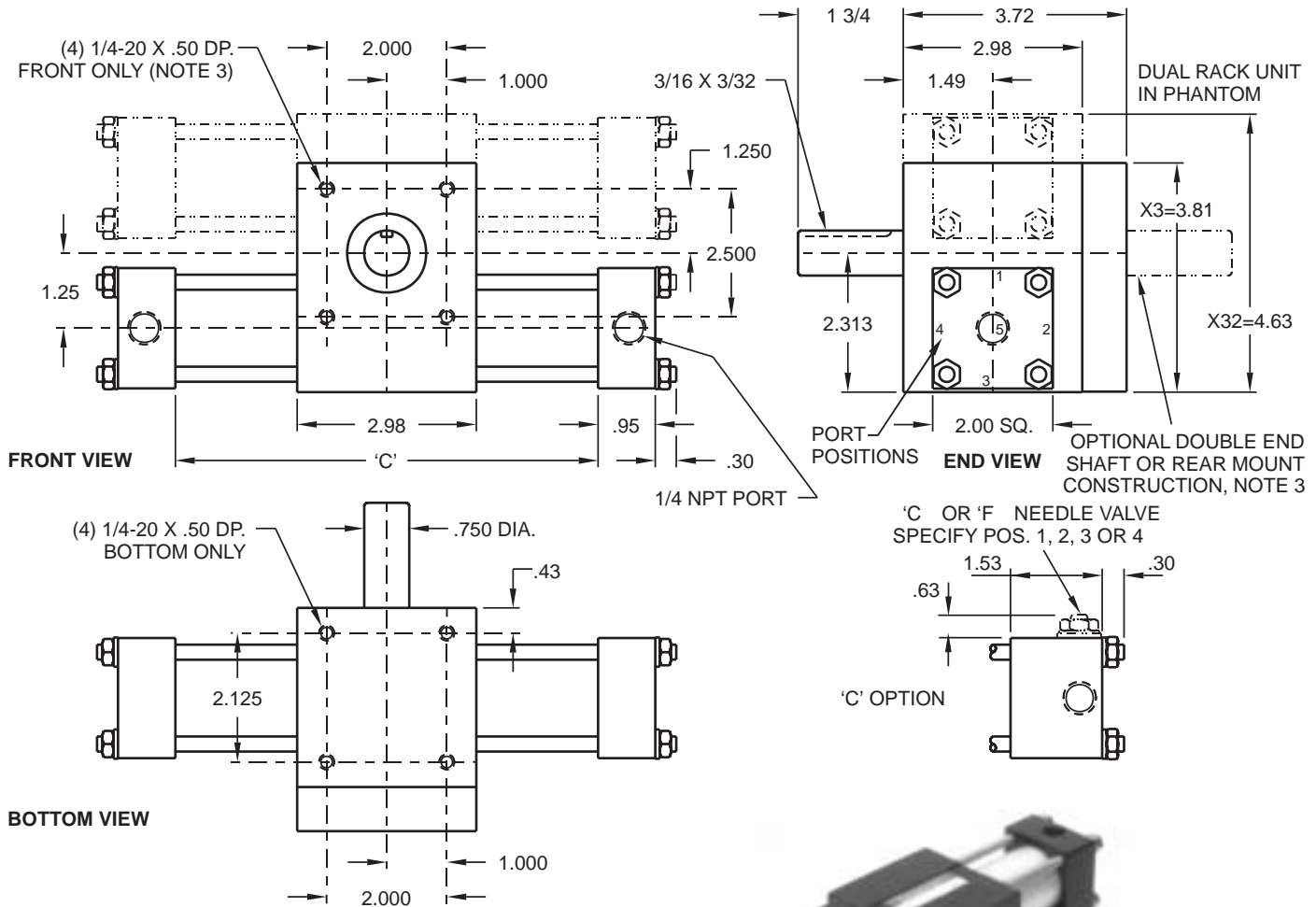

RATINGS

	X3	X32
Torque Factor: in. lb./p.s.i.	1.49	2.98
Max. Working Pressure, p.s.i.:	Air 120	60
	Oil 120	60
Max. Impact Energy: in. lb.	Front 8.9	8.9
	Rear 4	4
Max. Torque: Non-shock, in. lb.	196	196
Max. Reverse Torque: Non-shock, in. lb.	98	98
Max. Thrust: Non-shock, lb. ★	150	150
Max. Radial Load: Non-shock, lb.	80	80
Displacement: in ³ /deg.	.026	.052
Weight 180 deg. std. unit: lb.-oz.	7-9	9-9

★ -Thrust inward, front to rear only. Do not apply thrust in opposite direction.

ROTATION	'C' DIMENSION					ADD TO 'C' RESET SIDE
	X3		X32		'Q' OPT.	
	STD.	'G', 'R' OR 'S' OPT.	STD.	'G', 'R' OR 'S' OPT.		
12 DEG.	4.31	6.32	4.30	6.32		.06
15	4.41	6.37	4.40	6.37		
18	4.52	6.42	4.51	6.42		
22.5	4.68	6.50	4.67	6.50		
30	4.94	6.63	4.93	6.63		
36	5.15	6.74	5.14	6.74		
45	5.46	6.90	5.45	6.90		
60	5.99	7.16	5.98	7.16		
72	6.40	7.40	6.39	7.39		
90	7.03	8.03	7.02	8.02		
120	8.08	9.08	8.07	9.07		
180	10.17	11.17	10.16	11.16		
360	16.46	17.46	16.45	17.45		.06

NOTES:

1. An uncontrolled reset stroke can cause some bounce of the rack and a small forward impulse to the shaft. It will be apparent only if the shaft load is small, with low friction. It can be reduced by a bumper (usable on the reset cylinder only) or more by a correctly adjusted cushion.
2. Switch mounts by strap to cylinder; place as required for access and signal phasing.
3. For rear mount, order rear mount construction to reverse body and provide rear mount holes. Note reduced impact energy capacity, page 29.

INDEXING ACCURACY -0.2 deg.

SHAFT KEYWAY POSITION

Reference (start) position of shaft keyway:

30 _i indexer	11:30	345 _i
60 _i indexer	9:00	270 _i
120 _i indexer	6:00	180 _i
All others	12:00	0 _i

(Angles measured with respect to bottom of body.)

Accuracy of reference position

Optional high accuracy reference position
(not available on 15, 18 and 22.5 deg. units)

Symbol: KL



X4 & X42 INDEXING ACTUATORS

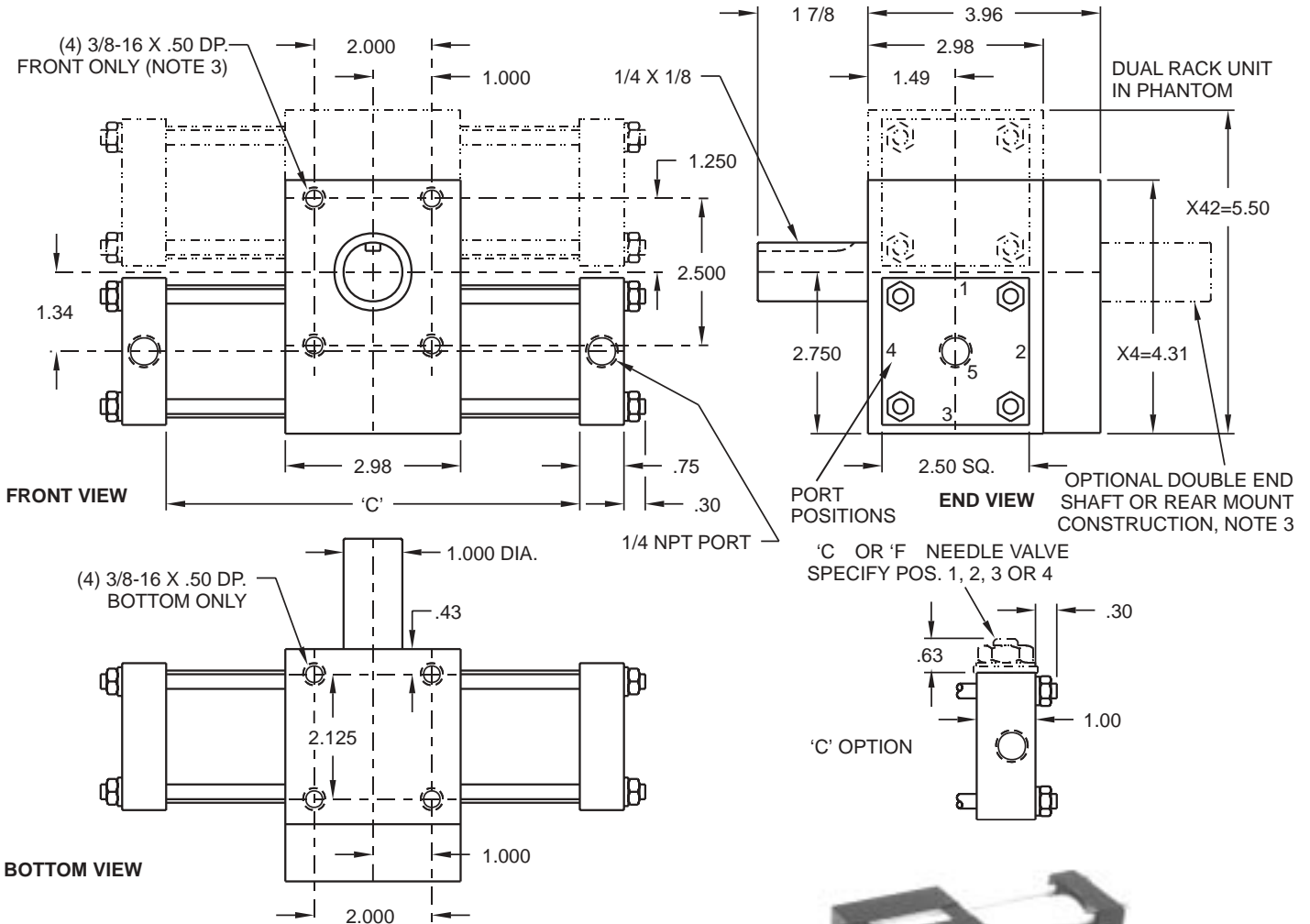

RATINGS

	X4	X42
Torque Factor: in. lb./p.s.i.	3.46	6.92
Max. Working Pressure, p.s.i.:	Air	120
	Oil	60
Max. Impact Energy: in. lb.	Front	17.4
	Rear	6.4
Max. Torque: Non-shock, in. lb.	412	412
Max. Reverse Torque: Non-shock, in. lb.	206	206
Max. Thrust: Non-shock, lb. *	180	180
	Max. Radial Load: Non-shock, lb.	150
Displacement: in ³ /deg.	.060	.121
Weight 180 deg. std. unit: lb.-oz.	10-13	15-13

* -Thrust inward, front to rear only. Do not apply thrust in opposite direction.

ROTATION	'C' DIMENSION				ADD TO 'C' RESET SIDE
	X4		X42		
STD.	'G', 'R' OR 'S' OPT.	STD.	'G', 'R' OR 'S' OPT.	'Q' OPT.	
12 DEG.	6.20	6.94	6.19	6.94	.06
15	6.31	7.00	6.30	7.00	
18	6.43	7.06	6.42	7.06	
22.5	6.60	7.14	6.59	7.14	
30	6.89	7.29	6.88	7.29	
36	7.12	7.40	7.11	7.40	
45	7.46	7.58	7.45	7.58	
60	8.04	8.04	8.03	8.03	
72	8.50	8.50	8.49	8.49	
90	9.19	9.19	9.18	9.18	
120	10.34	10.34	10.33	10.33	
180	12.65	12.65	12.64	12.64	
360	19.56	19.56	19.55	19.55	.06

NOTES:

1. An uncontrolled reset stroke can cause some bounce of the rack and a small forward impulse to the shaft. It will be apparent only if the shaft load is small, with low friction. It can be reduced by a bumper (usable on the reset cylinder only) or more by a correctly adjusted cushion.
2. Switch bracket mounts to tie rod; place as required for access and signal phasing.
3. For rear mount, order rear mount construction to reverse body and provide rear mount holes. Note reduced impact energy capacity, page 29.

INDEXING ACCURACY -0.2 deg.		
SHAFT KEYWAY POSITION		
Reference (start) position of shaft keyway:		
30j indexer	11:30	345j
60j indexer	9:00	270j
120j indexer	6:00	180j
All others	12:00	0j
(Angles measured with respect to bottom of body.)		
Accuracy of reference position		-2j
Optional high accuracy reference position (not available on 15, 18 and 22.5 deg. units)		-0.2j
Symbol: KL		



INDEXING SIMPLIFIED: CALCULATE IMPACT EASILY

Impact can displace work pieces, damage fixtures or the indexing actuator itself by breaking its shaft or ratchet key.

Avoid these effects by limiting rotational speed with a flow control; use the maximum available time consistent with cycle requirements.

CALCULATE MOMENT OF INERTIA

D = diameter
H = thickness, in
D = density, lb/in³
M = weight, lb
R = radius, in
L = length, in
A = width, in

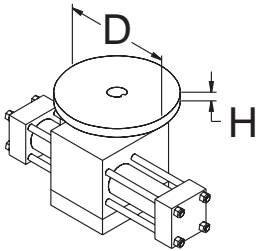

DISC:

$$J = \frac{D^4 \pi H D}{12365} \text{ in lb sec}^2$$

$$\text{or } J = \frac{M D^2}{3091}$$

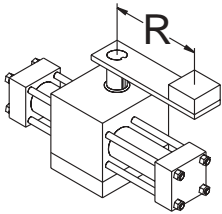

CONCENTRATED LOAD:

$$J = \frac{M R^2}{386.4} \text{ in lb sec}^2$$

PLATE ON AXIS:

$$J = \frac{M A^2}{4637} \text{ in lb sec}^2$$

$$\text{or } J = \frac{L \times H \times D \times A^2}{4637}$$

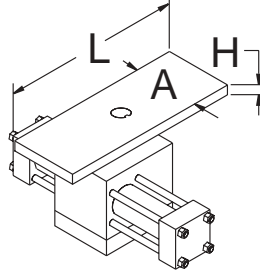
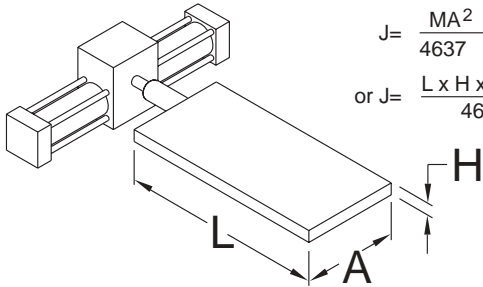

RECTANGULAR PLATE:

$$J = \frac{M(L^2 + A^2)}{4637} \text{ in lb sec}^2$$

$$\text{or } J = \frac{A H L D (L^2 + A^2)}{4637}$$

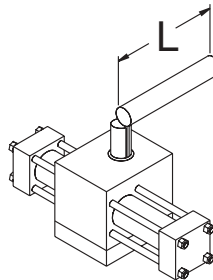

THIN ROD
AROUND ONE END:

$$J = \frac{M L^2}{1159} \text{ in lb sec}^2$$

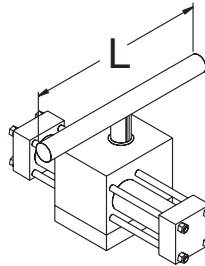

THIN ROD
AROUND CENTER:

$$J = \frac{M L^2}{4637} \text{ in lb sec}^2$$

CALCULATE IMPACT IN ROTARY MOTION

θ = angle of motion in radians, 1 radian = 57.3 degrees

w = angular velocity in radians/second

t = time duration of motion in seconds

For many pneumatic systems

$w = 2.3 \times \theta/t$ gives a reasonable estimate of maximum angular velocity

Impact energy:

W = impact energy in in lb

J = total moment of inertia of entire shaft load in in lb sec²

= J of workpiece + J of fixtures + J of supports member(s)

$W = 1/2 J w^2$

UNIT SELECTION

The following are maximum practical values of W for production use. They are based upon shaft tests to failure and provide a factor of safety of about 4 for shaft fracture. Though safe for the shaft, this impact may dislodge product or have other inertia effects.

UNIT	FRONT SHAFT	REAR SHAFT
X1 & X12	2.1 in lb	.4 in lb
X2 & X22	4	1.2
X3 & X32	8.9	4
X4 & X42	17.4	6.4



DESIGN YOUR STEPPING ACTUATOR

STEPS IN ONE DIRECTION WITHOUT HARD STOPS-GREAT FOR FEEDING, CROWDING, SPREADING



BORE	RACKS	SERIES SYMBOL
5/8	1	S1
1	1	S2
1	2	S22
1 3/8	1	S3
1 3/8	2	S32
2	1	S4
2	2	S42

ROTATION SYMBOL	
CLOCKWISE	CW
COUNTER CLOCKWISE	CCW

OPTION	OPERATION CONTROLLED			NEEDLE VALVE POSITION
	DRIVE	RESET	BOTH	
FLOW CONTROL	1F	2F	3F	1,2,3 or 4
CUSHION	1C	2C	3C	1,2,3 or 4
BUMPER	1Q	2Q	3Q	
ADJUSTABLE ROTATION	1A	2A	3A	

SEALS, NITRILE (STD.)	-
SEALS, FLUOROCARBON	V
SEALS, PRETENSIONED	T
SEALS, FLUOROCARBON PRETENSIONED	VT

SERIES	SYMBOL
S1	10.32*
S2,S22	1/8 NPT
S3,S32	1/4 NPT
S4,S42	1/4 NPT

*1/8 NPT OPTIONAL, NO COST
OTHER SIZES TO ORDER

PLATE	SYMBOL
BOTTOM	M
FRONT	N
REAR	P

SEE CATALOG PAGE 42

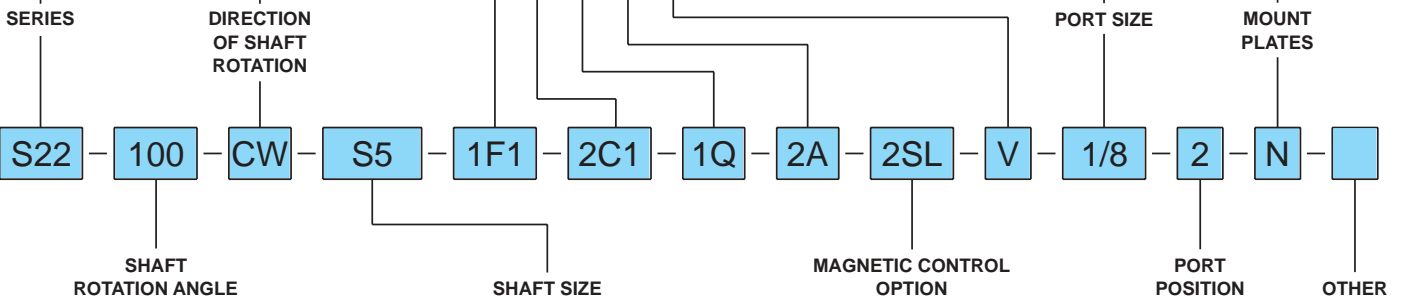

OPTIONAL ANGLES:
30, 45, 60, 90, 100, 120, 180, 190, 270, 360, 370, 540, 550, 720, 730, OR AS SPECIFIED

MULTI-ANGLE S22, S32 S42:
2 ANGLE: A-B
3 ANGLE: A-B-C
4 ANGLE: A-B-C-D

SUM TOTAL 360 DEG. MAXIMUM

SERIES	SYMBOL	OPTION SYMBOL
S1	S37	-
S2,S22	S5	D5
S3,S32	S75	-
S4,S42	S10	D10

DIMENSIONS: SEE CATALOG PAGE 43
SPECIALS: SEND SKETCH

S=SINGLE END 37=.375 DIA.
D=DOUBLE END 5=.500 DIA.
75=.750 DIA.
10=1.000 DIA.

POSITION	CONTROLS	OUTPUT CIRCUIT	LEAD
1	DRIVE	R	L
2	RESET	S	C
3	BOTH	G	
		N	

R=NPN Sink
S=PNP Source
G=Reed
N=No Switch Mag Only

PORT POSITION: 1, 2, 3, 4, 5
NO COST

HEAVY DUTY: A or K

NOTE: PORT CANNOT BE ON SAME SIDE AS NEEDLE VALVE

When an option is not required, leave blank.

Write out any special requirements in English or provide a dimensioned sketch. Rotomation can provide units to almost any configuration.

To expedite the order of a duplicate of a prior unit, refer to prior invoice/serial number stamped on the unit body.

Flow control and cushion cannot be installed in same end cap. Flow control in S1 10.32 port only.

SEAL REPAIR KITS
PART NUMBERS FOR SEAL REPAIR KITS

FILL IN UNIT SERIES AND ALL RELATED OPTIONS:
SRK - [S22] - [F] - [C] - [A] - [VT]

SERIES FLOW CUSHIONS ROTATION SEALS CONTROL ADJUSTERS

EXAMPLES:
SEAL KIT FOR S2-90-CW-S5-1F2-2A-V-1/8-1 = SRK-S2-F-A-V
NOTE: IF NO OPTIONS, SPECIFY SRK-S2-STD.

CALCULATED TORQUE IN INCH-POUNDS

Deduct 10% for friction

UNIT	OPERATING PRESSURE IN PSI				
	25	50	60	80	100
S1	3.8	7.6	9.2	12.3	15.3
S2	12.2	24.5	29.4	39.2	49
S22	24.4	49	58.8	-	-
S3	37.2	74.5	89.4	119	149
S32	74.5	149	-	-	-
S4	86.5	173	208	277	346
S42	173	346	415	-	-

STEPPING ACTUATOR OPERATION

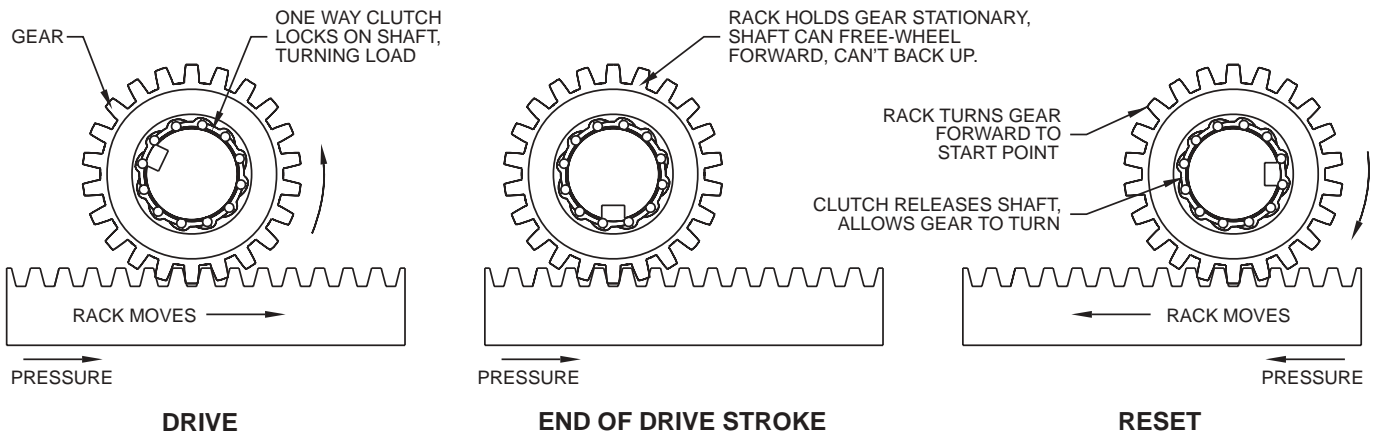

STEPPING ACTUATORS MOUNTING DIMENSIONS

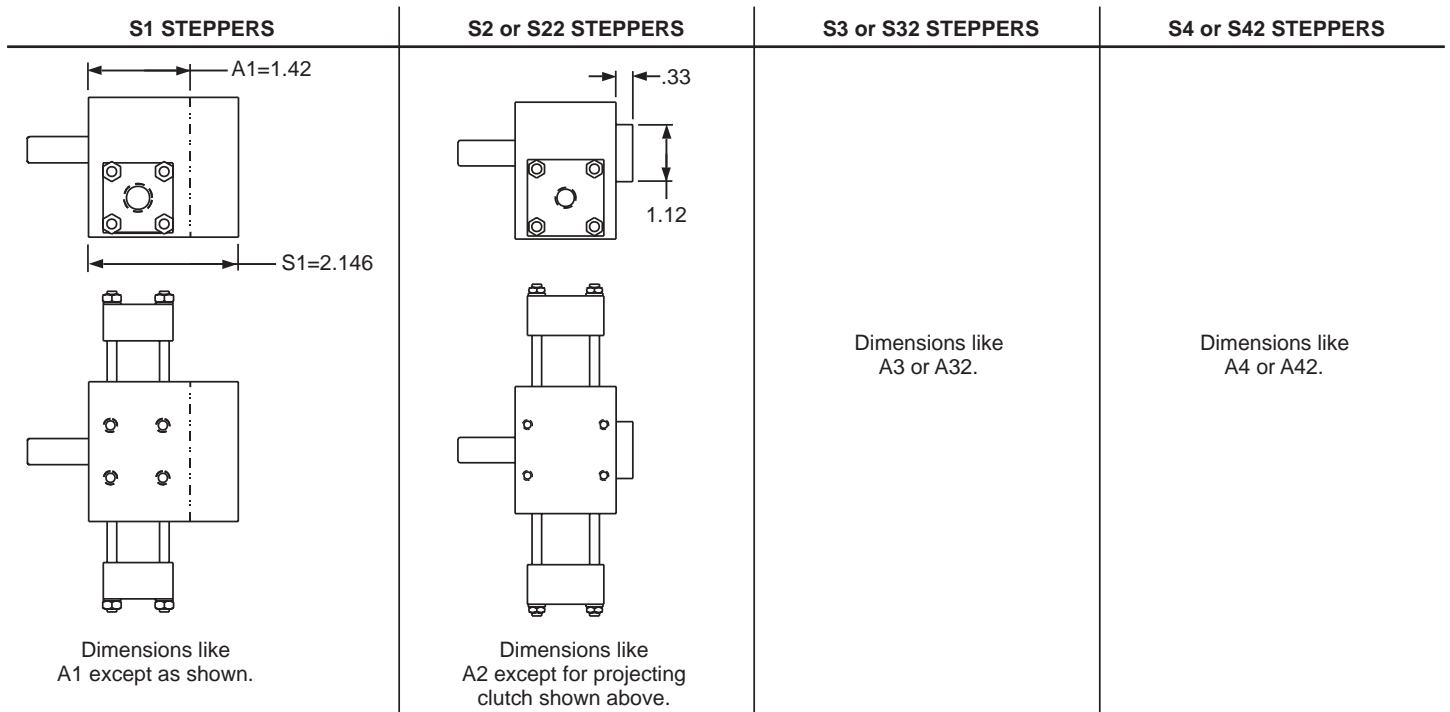

STEPPING ACTUATOR RATINGS

	S1	S2	S22	S3	S32	S4	S42
Torque Factor: in. lb./p.s.i.	.153	.49	.98	1.49	2.98	3.46	6.92
Max. Working Pressure, p.s.i.:							
Air	150	150	75	130	65	120	60
Oil	300	150	75	130	65	120	60
Max. Torque: Non-shock, in. lb.	45	73	73	196	196	412	412
Max. Reverse Torque: Non-shock, in. lb.	23	37	37	98	98	206	206
Max. Thrust: Non-shock, lb.	40	75	75	150	150	200	200
Max. Radial Load: Non-shock, lb.	40	75	75	150	150	200	200
Displacement: in ³ /deg.	.0026	.0086	.0172	.026	.052	.060	.121
Weight 180 deg. std. unit: lb.-oz.	1-2	2-7	3-12	6-2	8-12	8-14	13-14



HINTS ON USING A STEPPING ACTUATOR

The stepping actuator provides torque while rotating through its specified angle, always in one direction. It has no ability to slow or stop its load, so it will stop at a point determined by load inertia, friction, or external stops. The shaft can freewheel in the forward direction without restriction, so it has no fixed reference position. A one way clutch in the body prevents rotation in the reverse direction. Optional rotation adjusters can be used to set the stroke, and multiple stroke lengths can be obtained from a multi-angle actuator. The actuator can be stalled continuously by an external stop without problems.

Natural applications for the stepping actuator include:

- indexing applications where there is a high drag/inertia ratio and where error does not accumulate, such as driving a pinch roller to pull stock from a spool incrementally to be cut into lengths
- driving detented items such as rotary switches, cam sequences, etc
- those needing one-direction rotary motion with no position accuracy requirement, such as waste conveyors

Torque Ratings

The maximum torque is limited by the roller clutches used to drive the shaft and to prevent reverse rotation. Exceeding the maximum working pressure specified may overload the clutch, reducing life and/or causing immediate failure. Dual rack actuators are intended for use in applications where the maximum torque rating of the clutch cannot be utilized on normal shop air. Please note that normal shop air may overload the clutch on a dual rack actuator.

Reverse torque from an external source can also damage the actuator if it exceeds the maximum torque rating.

PRECISE POSITIONING/INDEXING

The stepping actuator can index even a high inertia load very precisely with a shot pin or other detent mechanism. The precision of the angle and load position is that of the detent system. This offers a number of advantages:

- The stop positions can be adjusted by adjustment of the detent position.
- Irregular, custom angle sequences are possible.
- The detent can be placed at a large radius to handle high inertia loads.

LOAD POSITION STABILITY

The shaft and load are prevented from rearward motion by the drive clutch and by a similar non-return clutch installed between the shaft and body. However, the clutches offer no resistance to forward motion, so torques in that direction will displace the shaft and load. Unwanted forward motion can be prevented by a controlled clutch/brake. Such a device can be installed on the rear projection of a double ended shaft.

DESIGN YOUR PBL3 PICK & PLACE ACTUATOR

MINIATURE-VACUUM THRU ROD-BUILT IN VACUUM PORT

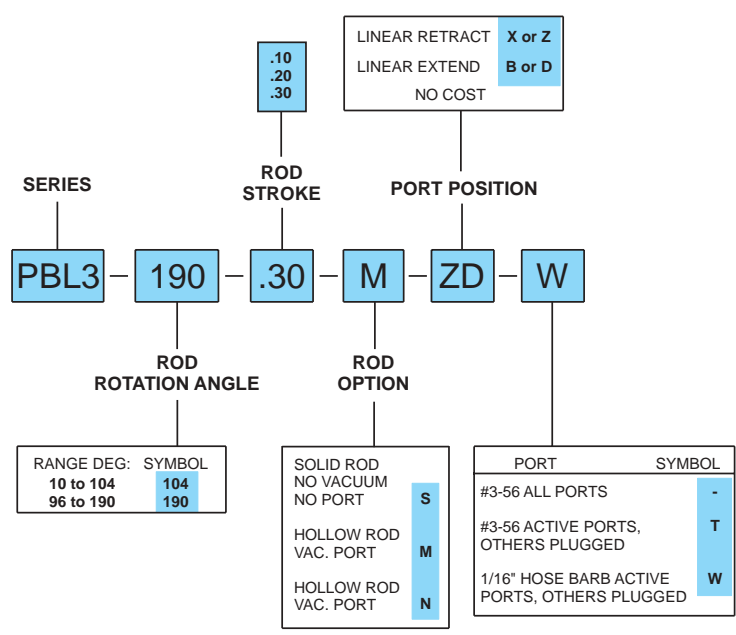

OPERATION

Pressure PSI	Torque In. Lb.	Push Lb.	Pull Lb.
20	.09	1.0	0.7
40	.18	1.9	1.4
60	.27	2.9	2.2
80	.36	3.9	2.9
100	.45	4.9	3.6

MAXIMUM RATINGS

Rotary Section-Max. Pressure Air	100 PSI
Linear Section-Max. Pressure Air	100 PSI
Torque	.45 In. Lb.
Rotary Actuator Disp.	.008 Cu. In. /94 Deg.
Weight	1.6 Oz.

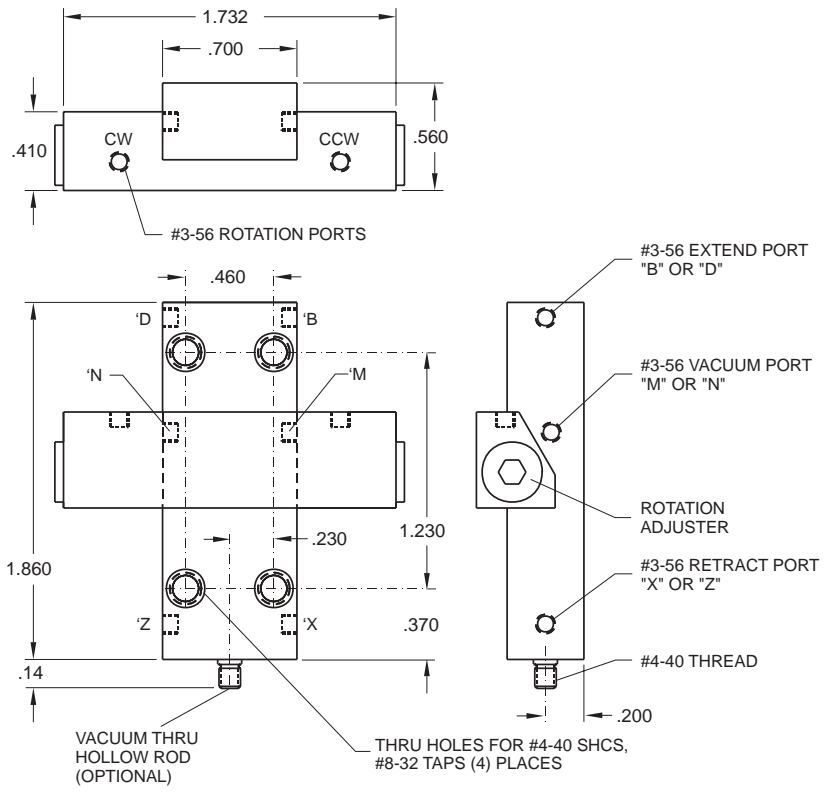

ORIENT PARTS

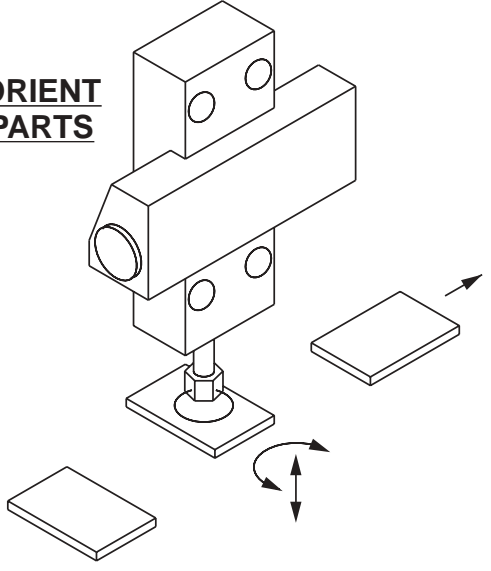

VACUUM CUP ADAPTERS

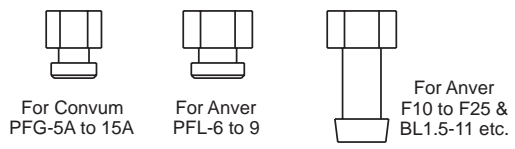

Purchase separately

DESIGN YOUR PBM3 PICK & PLACE ACTUATOR

MINIATURE-VACUUM THRU ROD-BUILT IN VACUUM PORT-MAGNETIC SWITCHES

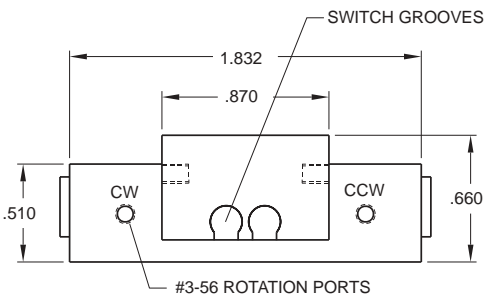
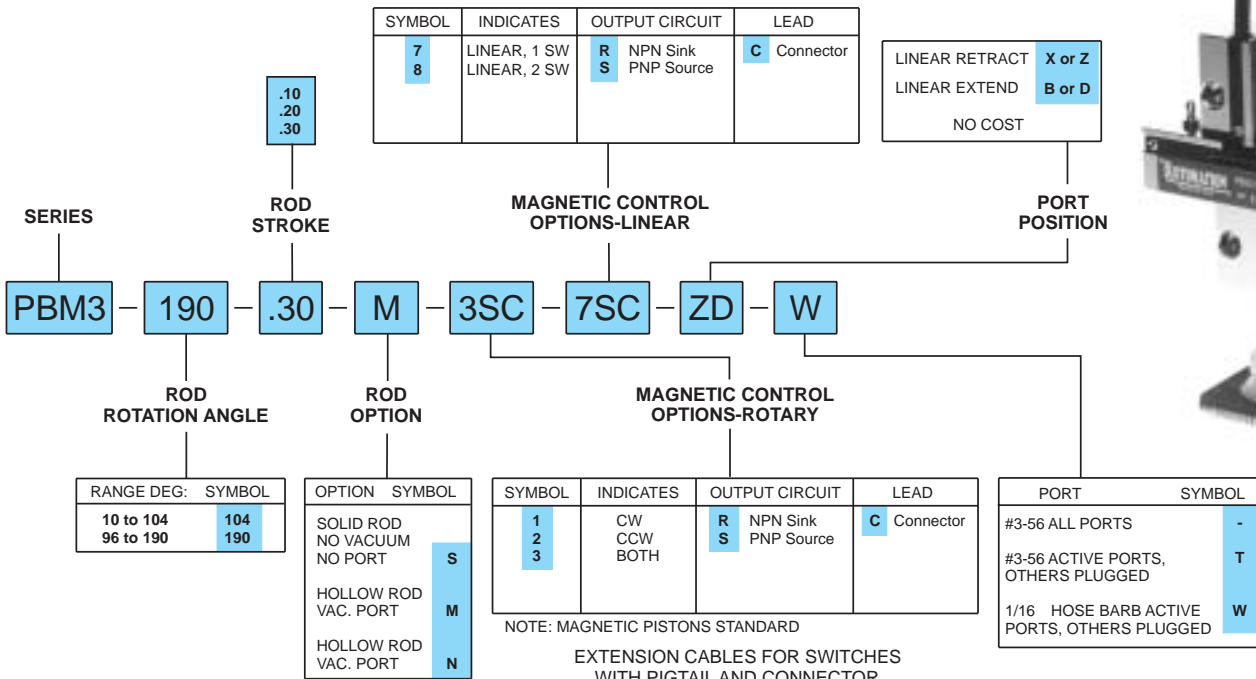

EXTENSION CABLES FOR SWITCHES WITH PIGTAIL AND CONNECTOR

ORDER SEPARATELY	
CABLE	PART NUMBER
2 METER LENGTH	CC2
5 METER LENGTH	CC5

OPERATION

Pressure PSI	Torque In. Lb.	Push Lb.	Pull Lb.
20	.09	1.0	0.7
40	.18	1.9	1.4
60	.27	2.9	2.2
80	.36	3.9	2.9
100	.45	4.9	3.6

MAXIMUM RATINGS

Rotary Section-Max. Pressure Air	100 PSI
Linear Section-Max. Pressure Air	100 PSI
Torque	.45 In. Lb.
Rotary Actuator Disp.	.008 Cu. In. /94 Deg.
Weight	2.0 Oz.

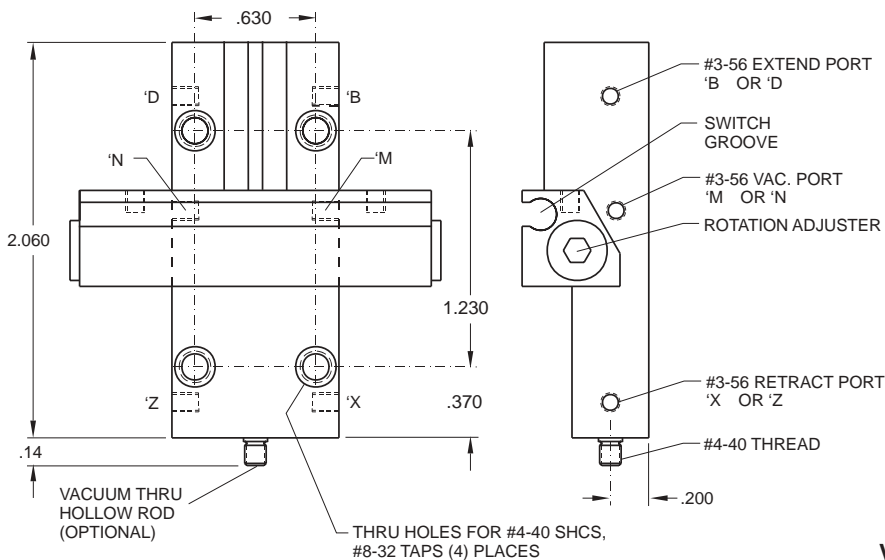

VACUUM CUP ADAPTERS

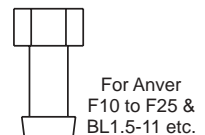
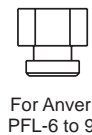
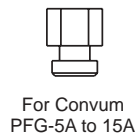

Purchase separately

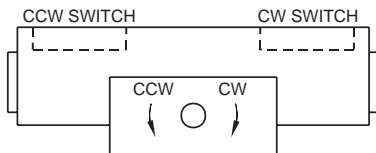

DESIGN YOUR PICK & PLACE ACTUATOR

When an option is not required, leave blank.

Write out any special requirements in English or provide a dimensioned sketch. Rotomation can provide units to almost any configuration.

To expedite the order of a duplicate of a prior unit, refer to prior invoice/serial number stamped on the unit body.

NEEDLE VALVE CANNOT BE ON SAME SIDE AS PORT.



TORQUE AT 100 PSI	ROT. BORE	RACKS	LINEAR BORE	SERIES SYMBOL
7	5/8	1	5/8	PA01
49	1	1	1 3/8	PA2
98	1	2	1 3/8	PA22
149	1 3/8	1	1 3/8	PA3
238 AT 80	1 3/8	2	1 3/8	PA32

LENGTH:
1, 2

OPTION	ROTATION DIRECTION CONTROLLED			NEEDLE VALVE POSITION
	CW	CCW	BOTH	
FLOW CONTROL	1F	2F	3F	1,2,3 or 4
CUSHION	1C	2C	3C	1,2,3 or 4
BUMPER	1Q	2Q	3Q	
ADJUSTABLE ROTATION	1A	2A	3A	

SEALS, NITRILE (STD.) -
SEALS, FLUOROCARBON V

LINEAR W, X, Y, Z
A, B, C, D
(PA01 A & C ONLY)
ROTARY
1, 2, 3, 4, 5
WA4 STD
NO COST

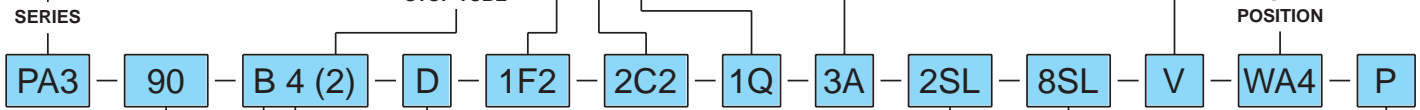

OPTIONAL ANGLES:
30, 45, 60, 90, 100, 120,
180, 190, 270, 360, 370,
540, 550, 720, 730,
OR AS SPECIFIED

MULTI-POSITION PA22 & PA32:
3 POS: A-P-B
4 POS: A-P-B/C
or A/B-P-C
5 POS: A/B-P-C/D

SEE CATALOG PAGE 39

TYPE	SYMBOL
STD., SHOWN	A
OPT. - FOR SMA	B
OTHER: SEND SKETCH	

AUX. SHAFT SYMBOL: D

POSITION	INDICATES	OUTPUT CIRCUIT	LEAD
1	CW	R NPN Sink	L 9' Lead
2	CCW	S PNP Source	C Connector
3	BOTH	G Reed	
4	3 POS., 4 SW	N No Switch	
5	4 POS., 6 SW		
6	5 POS., 8 SW		

SEE CATALOG PAGES 39, 40 & 41

PLATE	SYMBOL
BOTTOM SIDE	P
PA01 P ONLY	M
SEE CATALOG	
PAGE 42	

EXTENSION CABLES FOR SWITCHES WITH PIGTAIL AND CONNECTOR

ORDER SEPARATELY	
CABLE	PART NUMBER
2 METER LENGTH	CC2
5 METER LENGTH	CC5

POSITION	INDICATES	OUTPUT CIRCUIT	LEAD
7	LINEAR, 1 SW	R NPN Sink	L 9' Lead
8	LINEAR, 2 SW	S PNP Source	C Connector
		G Reed	
		N No Switch	
			Mag Only

SEE CATALOG PAGES 40, 41

NOTE: REED SWITCH "G" NOT AVAILABLE ON PA01.



SEAL REPAIR KITS

PART NUMBERS FOR SEAL REPAIR KITS

FILL IN UNIT SERIES AND ALL RELATED OPTIONS:

SRK - [PA2] - [F] - [C] - [A] - [V]
SERIES FLOW CONTROL CUSHIONS ROTATION ADJUSTERS SEALS

EXAMPLES:
SEAL KIT FOR PA2-90-A4-3C1-1A-3RL-WA4 = SRK-PA2-CA

NOTE: IF NO OPTIONS, SPECIFY SRK-PA2-STD.

DESIGN YOUR NITPICKER (INDEXING PICK & PLACE)

TO PROVIDE AN INDEXING ROTARY MOTION COMBINED WITH A LINEAR MOTION, CONSIDER THE NITPICKER, WHICH COMBINES THE X2 OR X22 ROTARY DRIVE WITH THE LINEAR MOTION FACILITY OF THE PA2 OR PA22.

CONFIGURATION IS SIMILAR TO THE PA2 OR PA22. FOR SPECIFICATION AND ORDERING DETAILS, CONSULT FACTORY; ASK FOR THE NITPICKER DESIGN CHART. FUNCTIONS AND OPTIONS ARE SIMILAR TO THOSE OUTLINED ABOVE BUT HAVE ROTARY CHARACTERISTICS OF THE X2 AND X22.

PA01 MINIATURE PICK & PLACE ACTUATOR

LOTS OF ACTION, TINY SPACE, TINY COST

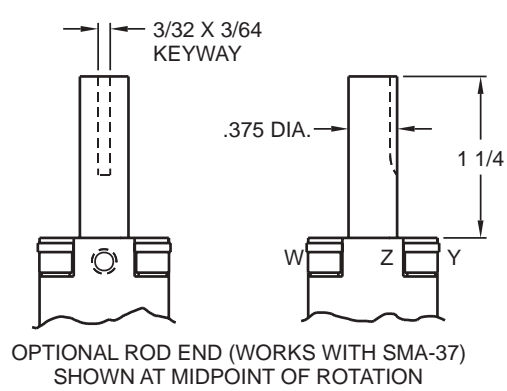
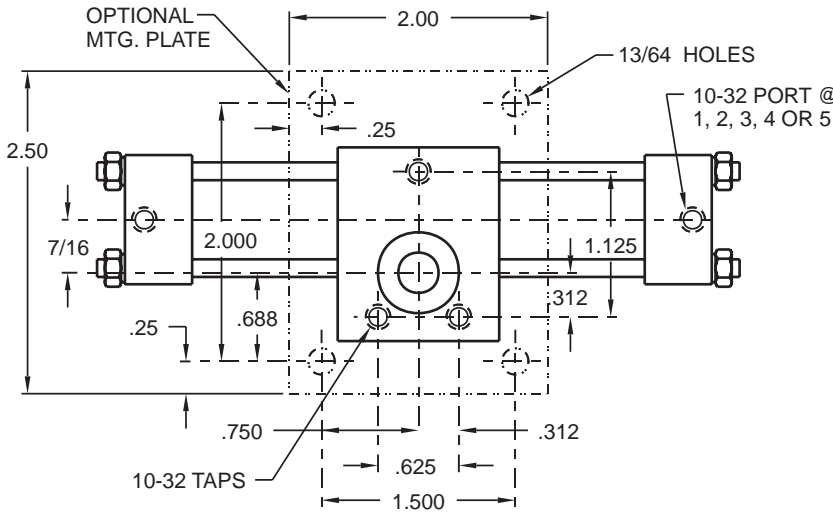
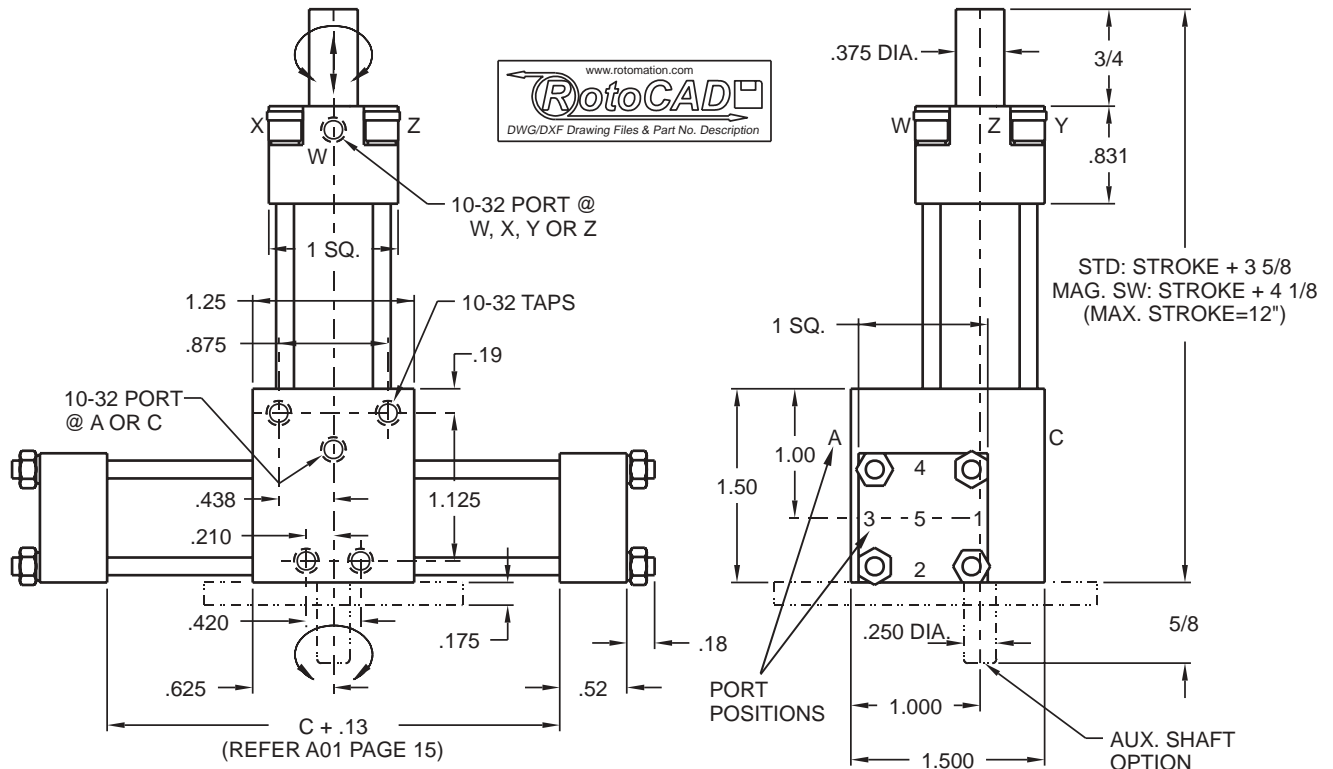

OPERATION

PRESSURE PSI	TORQUE-IN. LB.	PUSH LB.	PULL LB.
	(.07 X PSI)	(.3 X PSI)	(.19 X PSI)
60	4	18	11
80	5	24	15
100	7	30	19

Above figures are computed; output torques and forces are reduced by internal friction.

MAXIMUM RATINGS

ROTARY	PRESSURE, AIR	100
SECTION	PRESSURE, OIL	100
LINEAR	PRESSURE, AIR	100
SECTION	PRESSURE, OIL	100
TORQUE, NON-SHOCK, IN.-LB.		8
Rot. Act. Disp. in ³ /deg.		.0013
Weight 180 deg., 2" std. unit: lb.		0.9

Rotation Tolerance:
-0 +10 deg.

Backlash:
6 deg.

UNCONTROLLED IMPACT CAN CAUSE DAMAGE. LIMIT BOTH ROTATIONAL & LINEAR SPEEDS BY USE OF FLOW CONTROL IN EXHAUSTING CYLINDER.

MAGNETIC SWITCH OPTIONS

Solid state switches (R or S) are available on rotary and linear sections of unit. Switches mount to cylinders; place as required for access and phasing. Add 1/2" to cylinder length and unit height for linear switches.

NOTES:

1. Rotary options available are the same as A01.
2. Stop tubes are available to stabilize the extended shaft. Standard lengths are 1" and 2"; add to unit height. Sleeves for switch magnets serve the same function.
3. Needle valve: see page 15.



PA2 & PA22 PICK & PLACE ACTUATORS

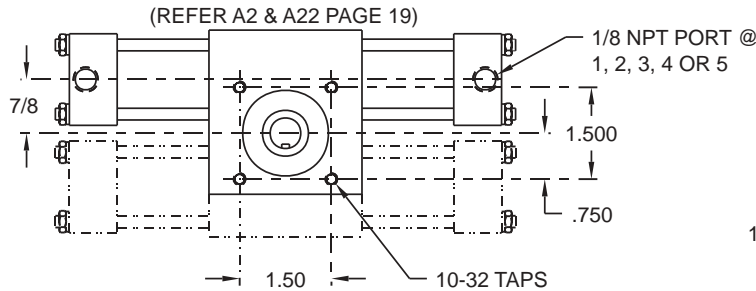
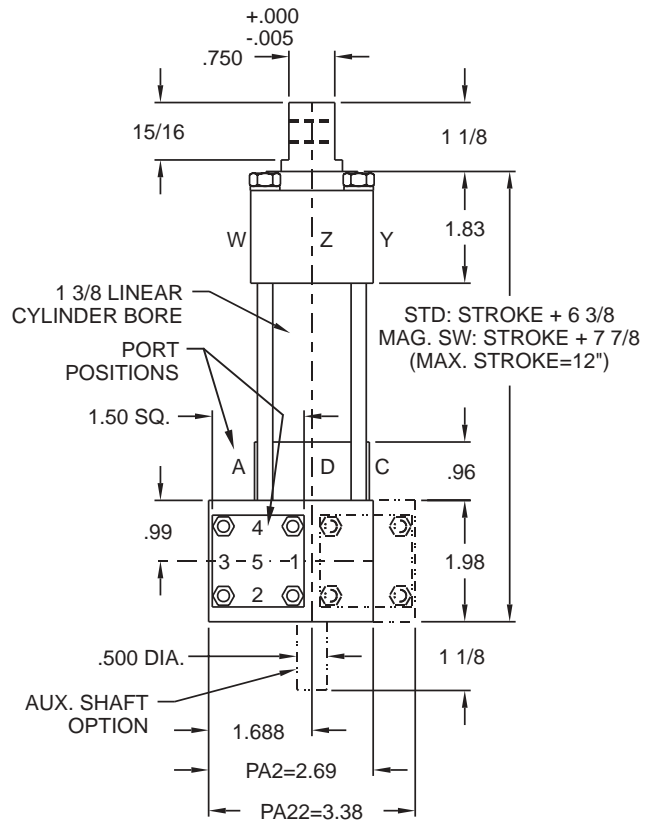
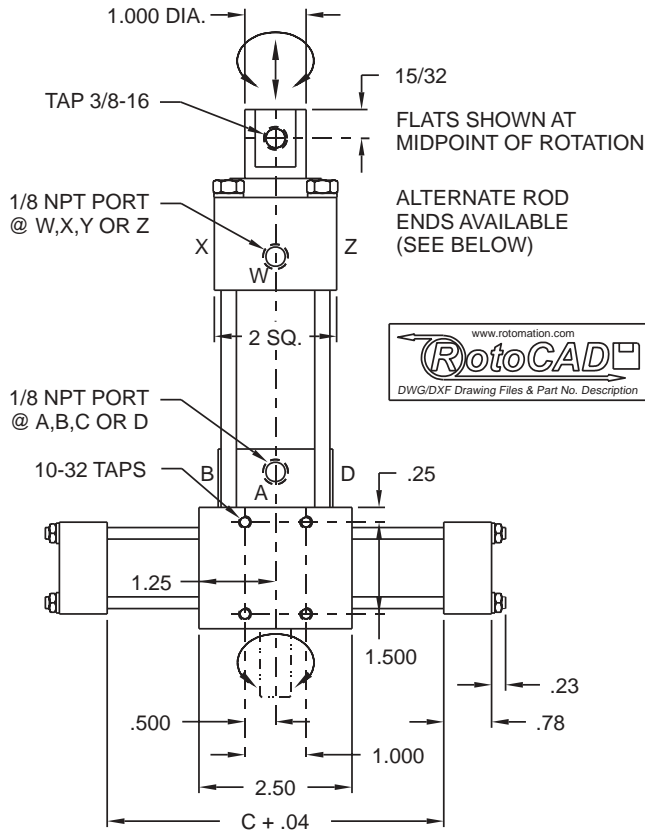

OPERATION

PRESSURE	TORQUE-IN. LB.		PUSH LB. (1.48 X PSI)	PULL LB. (.70 X PSI)
	PA2 (.49 X PSI)	PA22 (.98 X PSI)		
60	29	58	89	42
80	39	78	118	56
100	49	98	148	70
150	73	147	222	105
200	98	196	296	140
300	NA	NA	444	210
500	NA	NA	740	350

Above figures are computed; output torques and forces are reduced by internal friction.

**UNCONTROLLED IMPACT CAN CAUSE DAMAGE.
LIMIT BOTH ROTATIONAL & LINEAR SPEEDS BY
USE OF FLOW CONTROL IN EXHAUSTING CYLINDER.**

MAGNETIC SWITCH OPTIONS

Reed (G) and solid state switches (R or S) are available on rotary and linear sections of unit. Switches mount to cylinders; place as required for access and phasing.

ROTARY INSTALLATIONS:

Find C dimension in tables on A2 & A22 page.

LINEAR INSTALLATIONS:

Add 1 1/2" to cylinder length and unit height

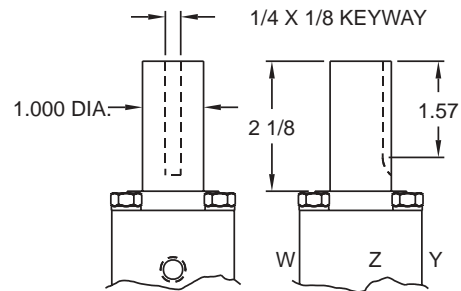

OPTIONAL ROD END (WORKS WITH SMA-10)
SHOWN AT MIDPOINT OF ROTATION

MAXIMUM RATINGS

		PA2	PA22
ROTARY	PRESSURE, AIR	250	250
SECTION	PRESSURE, OIL	250	250
LINEAR	PRESSURE, AIR	250	250
SECTION	PRESSURE, OIL	500	500
TORQUE, NON-SHOCK, IN.-LB.		200	250
Rot. Act. Disp: in ³ /deg.		.0086	.0172
Weight 180 deg., 2" std. unit: lb.		5.4	6.7

Rotation Tolerance:
PA2 & PA22 -0 +3 deg.

Backlash:
PA2 2 deg.
PA22 1 deg.

NOTES:

1. Stop tubes are available to stabilize the extended shaft. Standard lengths are 1" and 2"; add to unit height. Sleeves for switch magnets serve the same function.
2. Needle valve: see page 19.

PA3 & PA32 PICK & PLACE ACTUATORS

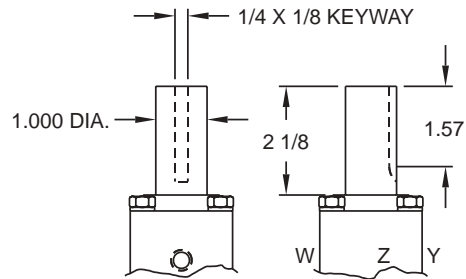
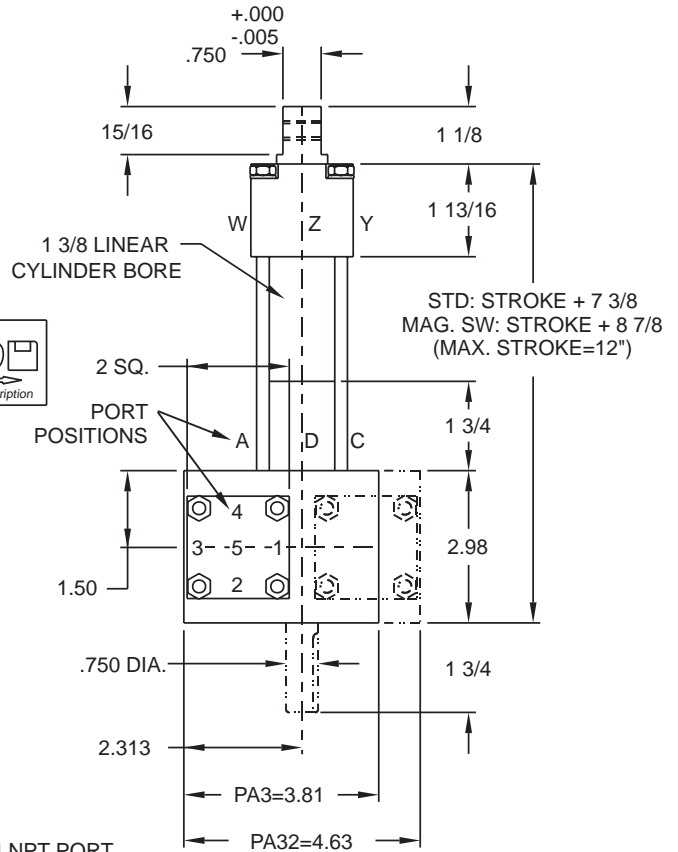
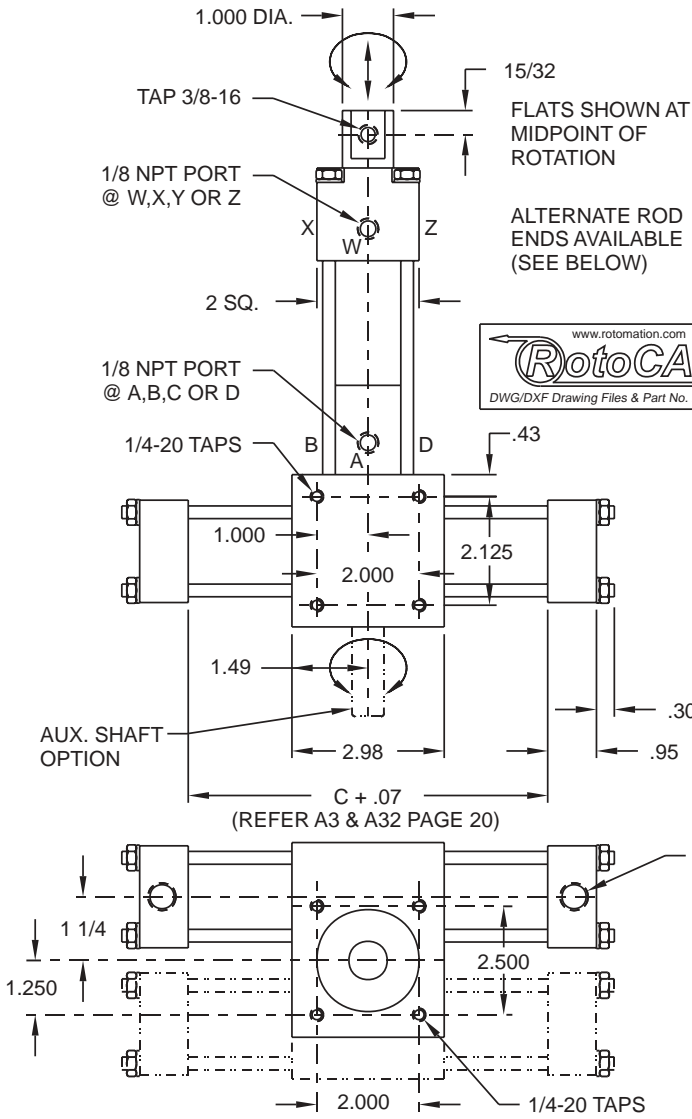

OPTIONAL ROD END (WORKS WITH SMA-10)
SHOWN AT MIDPOINT OF ROTATION

OPERATION

PRESSURE PSI	TORQUE-IN. LB.		PUSH LB.	PULL LB.
	PA3 (1.49 X PSI)	PA32 (2.98 X PSI)	(1.48 X PSI)	(.70 X PSI)
60	89	178	89	42
80	119	238	118	56
100	149	NA	148	70
150	223	NA	222	105
200	NA	NA	296	140
300	NA	NA	444	210
500	NA	NA	740	350

Above figures are computed; output torques and forces are reduced by internal friction.

**UNCONTROLLED IMPACT CAN CAUSE DAMAGE.
LIMIT BOTH ROTATIONAL & LINEAR SPEEDS BY
USE OF FLOW CONTROL IN EXHAUSTING CYLINDER.**

MAGNETIC SWITCH OPTIONS

Reed (G) and solid state switches (R or S) are available on rotary and linear sections of unit. Switches mount to cylinders; place as required for access and phasing.

ROTARY INSTALLATIONS:

Find C dimension in tables on A3 & A32 page.

LINEAR INSTALLATIONS:

Add 1 1/2" to cylinder length and unit height

MAXIMUM RATINGS

		PA3	PA32
ROTARY	PRESSURE, AIR	165	165
SECTION	PRESSURE, OIL	165	165
LINEAR	PRESSURE, AIR	250	250
SECTION	PRESSURE, OIL	500	500
TORQUE, NON-SHOCK, IN.-LB.		250	250
Rot. Act. Disp: in ³ /deg.		.026	.052
Weight 180 deg., 2" std. unit: lb.		9.2	11.9

Rotation Tolerance:

PA3 & PA32 -0 +2 deg.

Backlash:

PA3 2 deg.

PA32 1 deg.

NOTES:

1. Stop tubes are available to stabilize the extended shaft. Standard lengths are 1" and 2"; add to unit height. Sleeves for switch magnets serve the same function.
2. Needle valve: see page 20.



GENERAL AND MOTION CONTROL OPTIONS

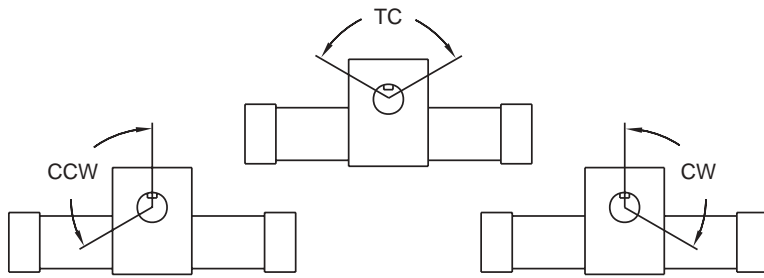

ACTUATOR SHAFT KEYWAY MOTION

Symbols specify orientation of arc of motion looking at front of unit. In Top Center (TC), the keyway passes thru 12:00 o'clock (0 deg.) at the midpoint of rotation; one-half the rotation is on either side of 12:00 o'clock.

Symbol: TC, CW, CCW No cost option.

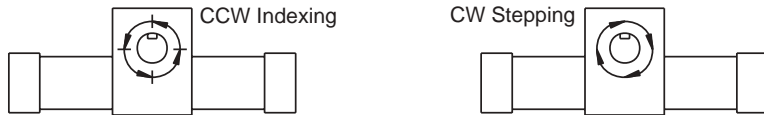

INDEXING & STEPPING ACTUATOR SHAFT KEYWAY MOTION

Specify shaft rotation looking at the projecting, load-carrying shaft.

Symbol: CW, CCW No cost option.

Indexing actuator: steps in specified direction to hard stops.
Stepping actuator: steps in specified direction, no hard stops. Accumulates error.

- Top 1
- Rear 2
- Bottom 3
- Front 4
- End 5

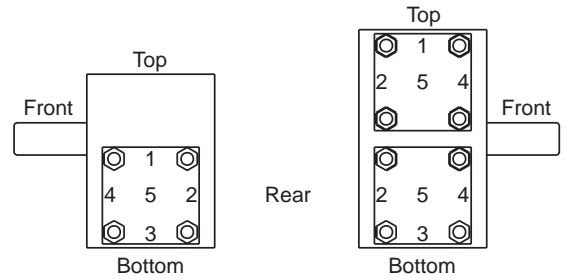

PORT POSITIONS 1, 2, 3, 4, 5 NEEDLE VALVE POSITIONS 1, 2, 3, 4

(PORT & NEEDLE VALVE CANNOT BE AT SAME POSITION)

Use numbered locations to specify desired position. No port in position 5 with options A, F or C. No port or needle valve between end caps in dual rack units; for positions 90 from shaft, specify 1, 3 (top and bottom).

Symbols: 1, 2, 3, 4, 5
No cost option.

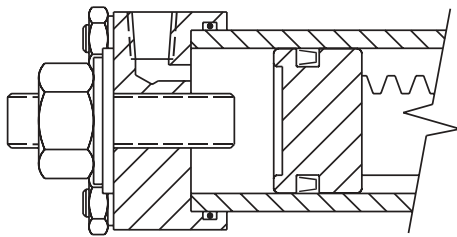

ROTATION ADJUSTER

Adjustable stop controls rotation over 30 deg. range by stroke reduction. Can be combined with flow control or cushion in single rack actuators or steppers. Not available for indexers.

Symbol: A

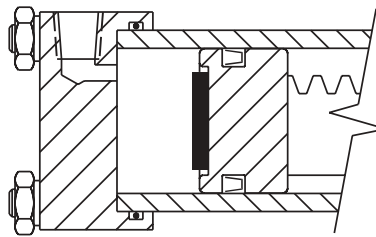

BUMPER

A urethane bumper is fastened to the piston face. It eliminates metal to metal contact and absorbs shock. Requires added cylinder length.

Symbol: Q

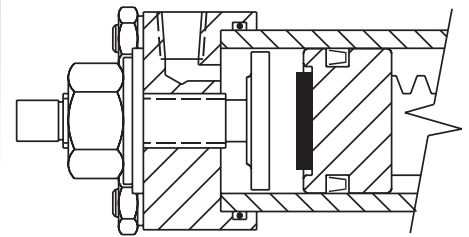

ADJUSTER AND BUMPER

Combination of adjuster and bumper. Uses enlarged adjuster face to distribute impact. Requires added cylinder length.

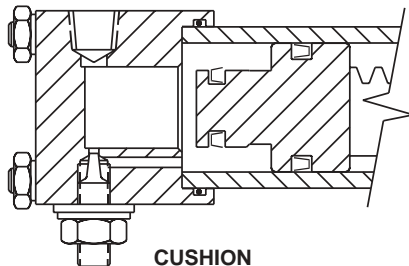

CUSHION

A reversed U-cup on the auxiliary piston closes the free passage to the port, forces exhaust through the control needle valve over last 30 deg. of rotation. For return, pressure folds U-cup down, allows full pressure and flow to piston.

Not fully effective in drive direction in steppers or indexers because of overrunning clutch.

Symbol: C

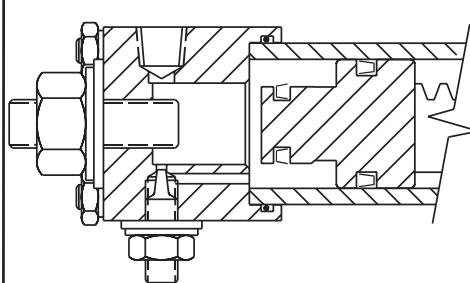

ADJUSTER AND CUSHION

Combined adjuster and cushion for single rack actuators or steppers. Installed separately, cushion on top rack, in dual rack units. Stroke reduction also reduces cushion action.

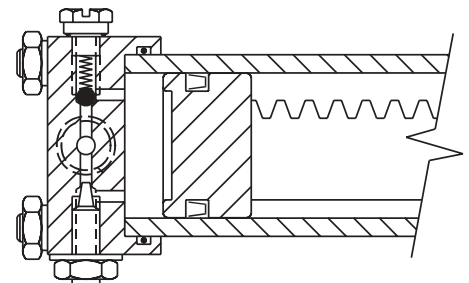

FLOW CONTROL

Forces exhausting air to pass through control needle valve, limits operating speed throughout rotation in one direction. Check valve opens for full flow on return. Requires needle valve access; not available with port position 5. Intended primarily for air operation. Can be combined with rotation adjustment.

Symbol: F

MOTION CONTROL OPTIONS



THREE POSITION ACTUATOR

Uses internal stops for optional drive to any of three shaft positions in any sequence. Available in A12, A22, A32 and A42, but drives shaft with only one cylinder at a time; use torque factor for A1, A2, A3 or A4.
Shown: A42-45-0-45-S11-C2-RR-1/4-1, 3

To specify the positions desired in a 3 position dual rack actuator:

1. Determine central reference position RP at 0° to 360° clockwise from 12:00
2. Determine angle CCW from RP: A
3. Determine angle CW from RP: B

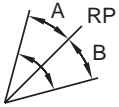

Specify: A-RP-B

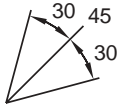

Example: 30-45-30

NOTE: MULTI-POSITION ACTUATORS REQUIRE TWO MAGNETIC SWITCHES TO INDICATE EACH INTERMEDIATE POSITION.



AIR DAMPERS

Auxiliary cylinders and pistons with adjustable pressurization through a relieving regulator give soft deceleration at cycle rates higher than conventional shock absorbers can tolerate.

Consult factory.



FOUR OR FIVE POSITION ACTUATORS

Pairs of auxiliary cylinders and pistons with stop rods added to three position actuators provide additional stop positions. All positions are accessible in any sequence. Note that intermediate end caps are vented.
Shown: four position A22-30/30-30-30-S5-1/8-4

FOUR POSITION:

To specify the positions desired in a 4 position dual rack actuator with auxiliary cylinders:

1. Determine an inner reference position RP at 0° to 360° clockwise from 12:00
 2. Determine angle CCW from RP: A
 3. Determine angles CW from RP: B & C
- Enclose RP with dashes, separate others with slash.

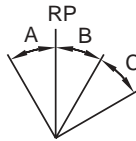

Specify: A-RP-B/C

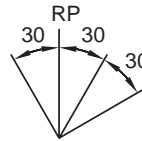

Example: 30-0-30/30

FIVE POSITION:

To specify the positions desired in a 5 position dual rack actuator with auxiliary cylinders:

1. Determine the central reference position RP at 0° to 360° clockwise from 12:00
 2. Determine angles CCW from RP: A & B
 3. Determine angles CW from RP: C & D
- Enclose RP with dashes, separate others with slash.

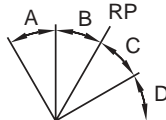

Specify: A/B-RP-C/D

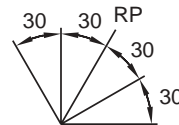

Example: 30/30-30-30/30

CONSTRUCTION OPTIONS



WASHDOWN UNITS

Shaft seals built into body or integral cover plates, cylinders sealed by O-Rings, assembly threads sealed, stainless shafts, anodized body and end caps.

Symbol: J

On order, hard chrome plated shafts, electroless nickel plated body and end caps.

DUST RESISTANT UNITS

Units sealed against inward leakage
Pressurization port

Symbol: Written description

CLEAN ROOM CONSTRUCTION

Units sealed against outward leakage
Body drain or purge ports
Low vapor pressure lubrication
Dry lubrication or wear rings

Symbol: Written description

SPECIAL SEALS

High temperature or aggressive fluids: FKM
Note bearing seal limitations.

Symbol: V

Minimum fluid leakage: Pretensioned seals.
Check fluid compatibility. Note increased breakaway pressure.

Symbol: T

HIGH PRESSURE CONSTRUCTION

For pressures to 750 psi. Steel cylinders (no magnetic switches), hydraulic pistons with backup rings or pretensioned seals as required. Thread inserts on tie rod anchors. Body drain if desired.

Symbol: HP

HEAVY DUTY, DUST RESISTANT A4, A42, X4, X42

Sealed, non-pumping structure-dust stays out. Pistons: two PTFE wear rings, carboxylated nitrile seals.

Cylinders: hard chrome ID, epoxy OD or aluminum with hard coat ID.

Lube: extra-tacky air cylinder grease.

Symbol: A or K

REAR MOUNT CONSTRUCTION X3, X32, X4, X42

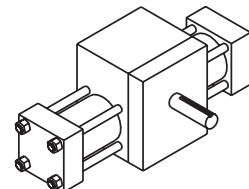

Shaft projects from rear; front mount holes opposite. Specify shaft rotation and options relative to shaft. Note reduced impact capacity page 29.

Symbol: B

SIGNAL OPTIONS - MAGNETIC SWITCHES

TIE ROD UNITS



Two types of clamps are shown. Tie rod or strap clamps are supplied to fit best on the unit for which they are specified.

UNITS WITHOUT TIE RODS

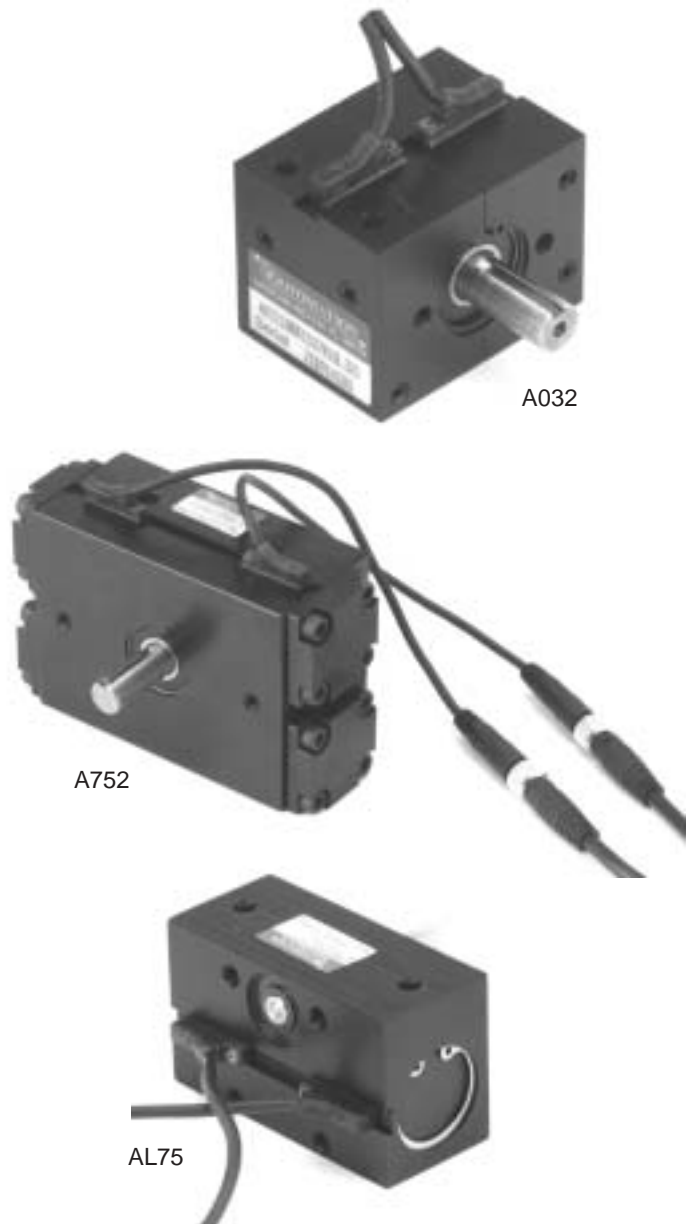

Switch position is adjustable along the integral track and locked by a hex socket set screw. Pigtail leads with connectors as shown on the A752 are optional on all switches; the extension cables should be ordered separately.

SET UP AND OPERATION

Adjust switch position along exhausting cylinder to phase signal for desired sequence.

Adjustable range: 30 deg. or 1/2 stroke, whichever is smaller.

Keep magnetic materials away.

Multi-position actuators require two switches to indicate each intermediate position; a single switch will indicate each end position.

Rotation piston magnets and switches are designed to work together. Magnets or switches may or may not work with components of other manufacture.

MOUNT PLATE OPTIONS



REAR MOUNT PLATE P



FRONT MOUNT PLATE N



BOTTOM MOUNT PLATE M

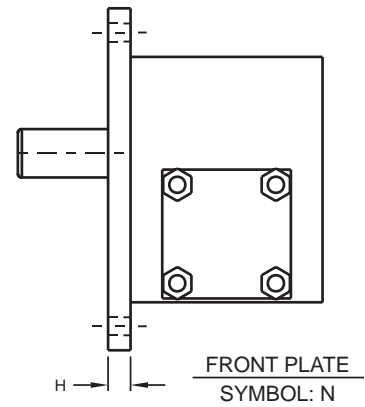
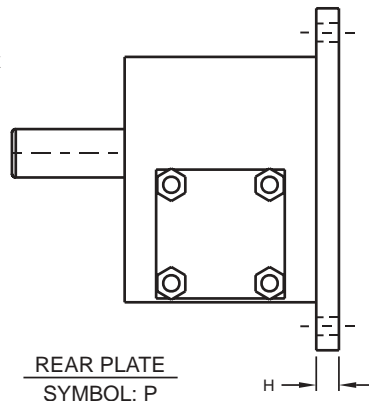
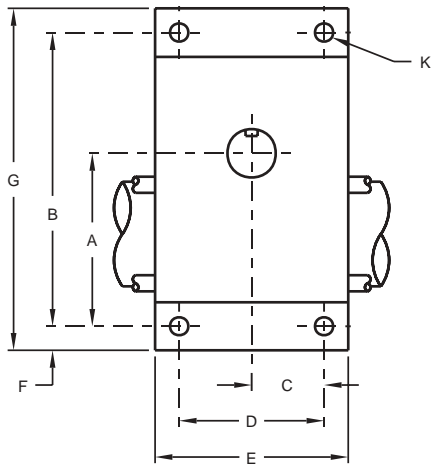

INDEXING ACTUATORS: Rear plate P fits X1, X12, X2, X22; for X3, X32, X4 & X42 specify BP: rear mount construction and plate.

STEPPING ACTUATORS: Rear plate P not usable on S2 OR S22; others ok.

PICK AND PLACE ACTUATORS AND NITPICKERS: Mount plate P (perpendicular to rod) same as listed plate for corresponding actuator or indexer.

DIMENSIONS

MODEL	A	B	C	D	E	F	G	H	I	J	K	Z
A01	1.188	1.875	.313	.625	1.00	3/16	2.25	.175	1.375	1.75	3/16	.188
PA01	1.312	2.000	.750	1.500	2.00	1/4	2.50	.175	NA	NA	13/64	.188
A032	1.000	2.000	.750	1.500	2.00	1/4	2.50	.175	2.000	2.50	7/32	.250
A1	1.500	2.500	.750	1.500	2.00	1/4	3.00	.175	2.500	3.00	7/32	.563
S1	1.500	2.500	.750	1.500	2.00	1/4	3.00	.175	3.125	3.63	7/32	.563
A12	1.500	3.000	.750	1.500	2.00	1/4	3.50	.175	2.500	3.00	7/32	.563
X1	1.500	2.500	.750	1.500	2.00	1/4	3.00	.175	3.125	3.63	7/32	.250
X12	1.500	3.000	.750	1.500	2.00	1/4	3.50	.175	3.125	3.63	7/32	.250
A2 or S2	1.938	3.188	.750	1.500	2.50	1/4	3.69	.235	2.500	3.00	7/32	.250
A22 or S22	1.938	3.875	.750	1.500	2.50	1/4	4.38	.235	2.500	3.00	7/32	.250
X2	1.938	3.188	.750	1.500	2.00	1/4	3.69	.235	3.500	4.00	7/32	.250
X22	1.938	3.875	.750	1.500	2.00	1/4	4.38	.235	3.500	4.00	7/32	.250
A3 or S3	2.687	4.562	1.125	2.250	3.00	3/8	5.31	.350	3.750	4.50	9/32	.375
A32 or S32	2.687	5.375	1.125	2.250	3.00	3/8	6.13	.350	3.750	4.50	9/32	.375
X3	2.687	4.562	1.125	2.250	3.00	3/8	5.31	.350	4.500	5.25	9/32	.375
X32	2.687	5.375	1.125	2.250	3.00	3/8	6.13	.350	4.500	5.25	9/32	.375
A4 or S4	3.125	5.063	1.125	2.250	3.00	3/8	5.81	.350	3.750	4.50	11/32	.375
A42 or S42	3.125	6.250	1.125	2.250	3.00	3/8	7.00	.350	3.750	4.50	11/32	.375
X4	3.125	5.063	1.125	2.250	3.00	3/8	5.81	.350	4.750	5.50	11/32	.375
X42	3.125	6.250	1.125	2.250	3.00	3/8	7.00	.350	4.750	5.50	11/32	.375

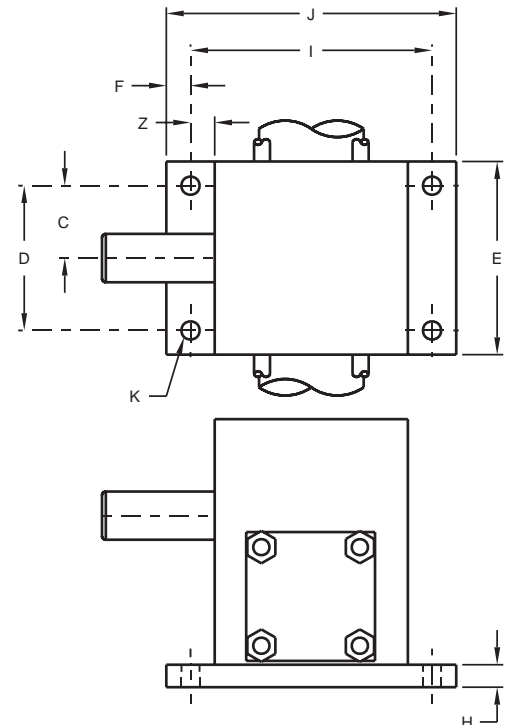

BOTTOM PLATE
SYMBOL: M

For PA01, see pg. 35

MATCH YOUR LOAD WITH SHAFT OPTIONS



DOUBLE END SHAFT

Shaft extends from the rear of the unit as well as the front. Rear projection dimensions same as front.

Symbol: D(SIZE)

A42-180-CCW-D11-3C2-1/4-1&3 shown.



HOLLOW SHAFT

Provides compact coupling to load; dimension table below. Self aligning if mounted free on driven shaft with turnbuckle to absorb torque.

Symbol: HS(SIZE)

A42-180-TC-HS75-3C2-1/4-1&3 shown.

PRELOADED KEYWAY

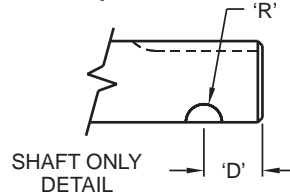
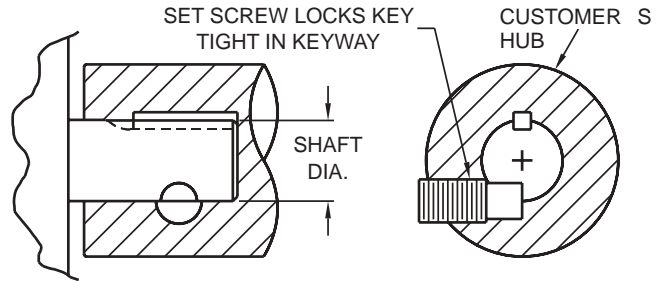

Unit Size	Shaft Dia.	'R'	'D'
1 or 12	.375	.125	.312
2 or 22	.500	.156	.375
3 or 32	.750	.188	.688
4 or 42	1.000	.250	.812
	1.125	.250	.812

Symbol: KK

STANDARD AND OPTIONAL SHAFT CONFIGURATIONS

SHAFT DIAMETER:	3/16			1/4			3/8			3/8 ID	1/2			3/4			3/4 ID	1			1 1/8	
SHAFT SYMBOL:	S18	S25	D25	R25	S37	D37	R37	HS37	S5	D5	S75	D75	R75	HS75	S10	D10	R10	S11	D11			
A032		O	O	O	S	O	O*															
A01	O	S	O																			
A1 or A12		O			S	O		O														
S1					S																	
X1 or X12					S	O																
AL75		S	O	O																		
A752					S	O		O														
A2 or A22								O	S	O												
S2 or S22									S	O												
X2 or X22									S	O												
A3 or A32											S	O		O								
S3 or S32											S											
X3 or X32											S	O	O									
A4 or A42														O	S	O				O*	O	
S4 or S42															S	O						
X4 or X42															S	O	O					

REAR PROJECTING SHAFT A032

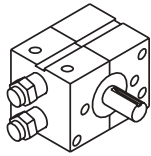

Specify options from front view of unit. Rear projecting shaft operates like rear half of double ended shaft.

Abbreviations: "S18" means "single ended shaft .188" (3/16") diameter; others similar. "D18" means "double ended shaft .188" (3/16") diameter; others similar. "R37" means "rear projecting shaft .375" (3/8") diameter; others similar. "HS37" means "hollow shaft .375" (3/8") inside diameter; others similar. "S" means "standard". "O" means "optional".

* No cost option; all other optional shaft configurations at slight additional cost.

HOLLOW SHAFT

UNIT	SHAFT SYMBOL	SHAFT I.D.	KEYWAY	SHAFT O.D.	STD. BRG.	SET SCREW
A1, A12 & A752	HS37	.3755/.3765	3/32 X 3/64	.625	BRONZE	8-32
A2, A22	HS37	.3755/.3765	3/32 X 3/64	.750	BALL	8-32
A3, A32	HS75	.751/.752	3/16 X 3/32	1.378	BALL	10-32
A4, A42	HS75	.751/.752	3/16 X 3/32	1.378	BALL	10-32

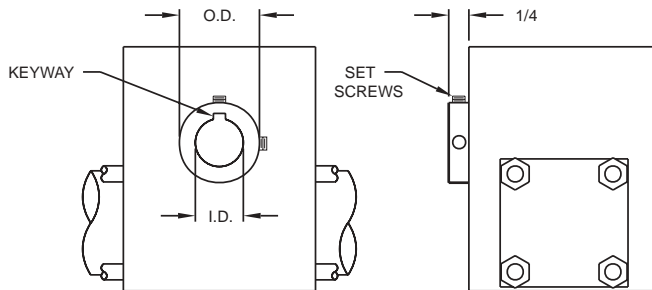

SPECIAL SHAFTS:

Specify or sketch:

- Length or projection
- Diameter
- Keyway
- Drill or tap
- Retaining ring groove
- Bore
- Wrench flats
- Material
- Heat treat
- Plating

Most configurations in short time at low cost.

Ask for quotation.

SHAFT MOUNTING ADAPTERS

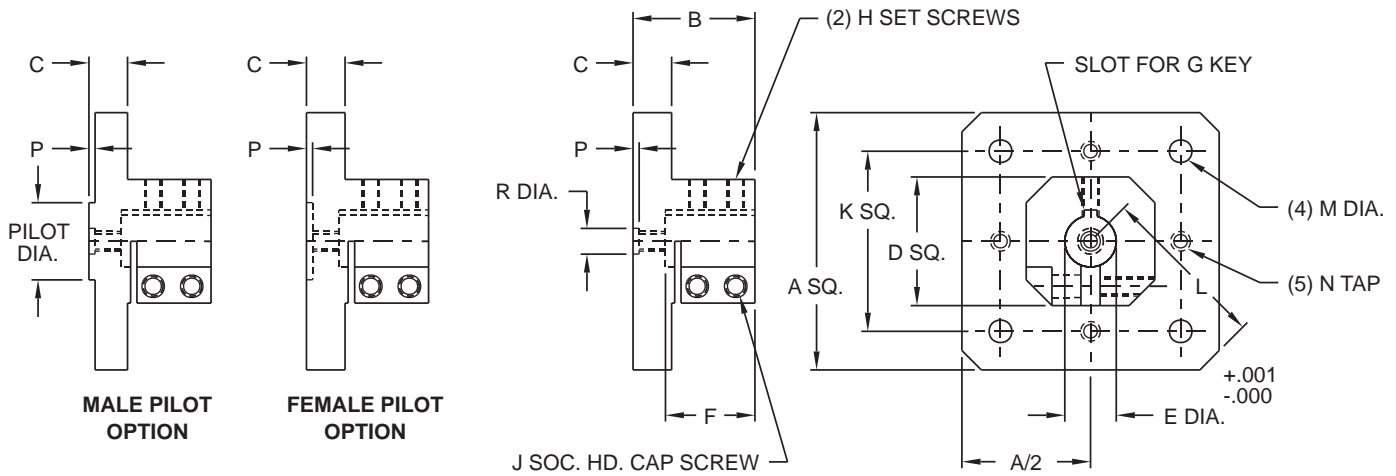

DIMENSIONS																
SIZE	SHAFT DIA.	A	B	C	D	E	F	G	H	J	K	L	M	N	P	R
37	.375	2.00	1.063	.313	1.00	.375	.750	3/32 X .75 LG.	6-32	#8-32	1.375	1.22	.219	#10-32	.060	.250
50	.500	2.50	1.188	.375	1.25	.500	.813	1/8 X .81 LG.	6-32	#10-32	1.750	1.64	.219	#10-32	.060	.250
75	.750	3.50	1.875	.500	1.63	.750	1.375	3/16 X 1.38 LG.	10-32	1/4-20	2.500	2.25	.281	1/4-20	.060	.313
10	1.000	4.00	2.125	.625	2.25	1.000	1.500	1/4 X 1.50 LG.	1/4-20	5/16-18	3.000	2.56	.406	3/8-16	.125	.438
11	1.125	4.00	2.125	.625	2.25	1.125	1.500	1/4 X 1.50 LG.	1/4-20	5/16-18	3.000	2.56	.406	3/8-16	.125	.438

-ORDERING INFORMATION-

SMA - 50 - W - M.060



SIZE

SHAFT DIA.	SYMBOL
.375	37
.500	50
.750	75
1.000	10
1.125	11

HOLES

HOLES	SYMBOL
AS SHOWN	W
CENTER HOLE ONLY	N
USER SPECIFIED HOLES	SXXX FOR SPECIAL DRILL PATTERN

PILOT

PILOT	SYMBOL
REFERENCE BORE ONLY	LEAVE BLANK
MALE PILOT	MX.XXX WHERE X.XXX IS PILOT DIA., INCHES
FEMALE PILOT	FX.XXX WHERE X.XXX IS PILOT DIA., INCHES

NOTES:

- Material: Clear anodized aluminum.
- User specified holes: Send drawing. Factory will assign number XXX.
- Adapters are stocked with no holes and with holes as shown. Special hole patterns and pilots are normally added after anodize and will expose bare aluminum.
- Keyway is aligned with sides of plate. Reference bore 'R' is concentric with shaft bore within .001.
- Shaft mounting adapters shipped with key, clamp screws & set screws.
- Pilot diameter tolerance is $\pm .002$.

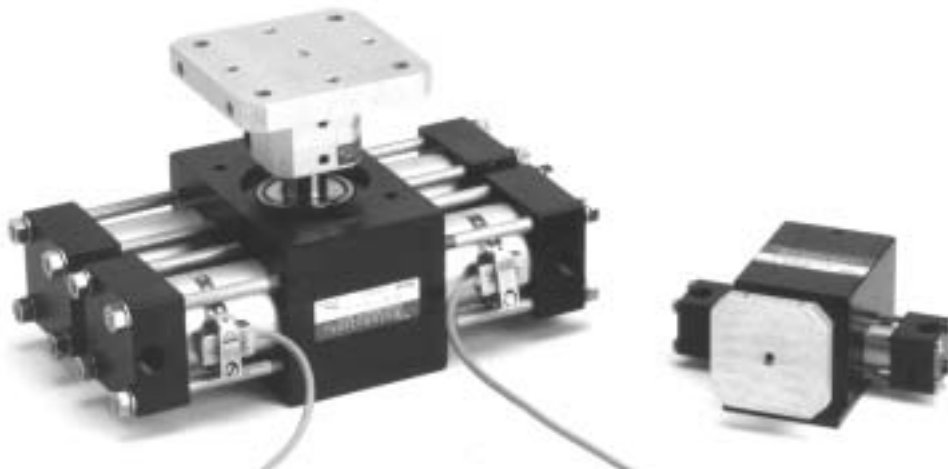

HYDRAULIC SWING CLAMP

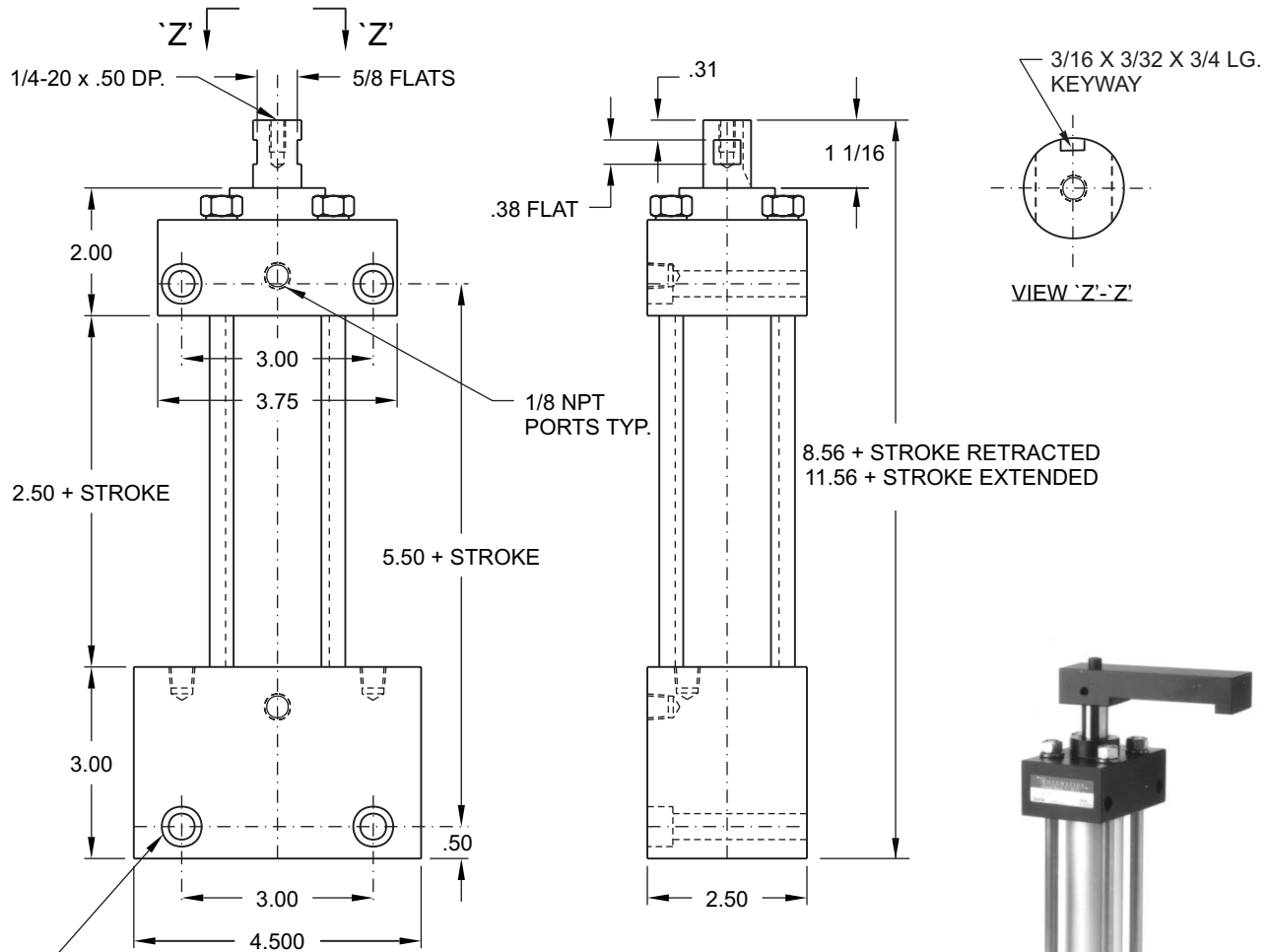

(4) .406 (13/32) THRU HOLES, WITH 5/8 C'BORE, NEARSIDE

CLAMP PART NUMBER

CL5 - **CW** - **3** - **S_**

SERIES ROTATION DIRECTION STROKE SPECIAL FEATURES

(Send dimensioned sketch, factory will assign number)



DESCRIPTION:

Clamp rod and arm extended and retracted by 1.375 bore cylinder with .750 diameter rod. Rod and arm rotated 90 deg. by rack and pinion actuator. Extend/retract and rotation separately plumbed and controlled.

RATINGS

Maximum Working Pressure, p.s.i.:	500
Maximum Clamping Force, lbs.:	528
Maximum Extend Force, lbs.:	742
Clamp Arm Rotation, deg.:	90
Bore Diameter:	1.375"
Rod Diameter:	.750"

OPTIONS

Stroke:	.5" To 8"
Ports:	1/8" NPT

CONSTRUCTION:

Rod: Chrome Plated 303 Stainless Steel
 Body: 6061 Aluminum, Electroless Nickel Plated
 End Cap: 2024 Aluminum, Black Anodized
 Tie Rods & Nuts: 303 Stainless Steel

SPECIAL ORDER:

Rod End Detail: Send Dimensional Sketch
 Port & Mount Hole Size & Location
 Materials
 Finishes

READY REFERENCE - INSTALLATION & OPERATION

GENERAL

Torque and thrust data given in the brochure are theoretical and intended as a guide to performance. Applications, including specification of required unit size, etc. are the responsibility of the user. Rotomation will handle repair or replacement expeditiously, making all reasonable efforts to provide same day shipment via overnight air on items received by that routing, but cannot be responsible for consequent or other related costs.

Improvements are frequent and designs are subject to change without notice; mounting dimensions are kept unaltered for interchangeability.

User notation of the invoice number or the serial number stamped on the unit body will enable duplication of prior units.

ACTUATOR AND INDEXER SHOCK LOADS

In many cases, an actuator or indexer must be sized for the load it will stop rather than the operating torque requirement. Avoid impact loads caused by load momentum; their energy can break the shaft or gear and rack teeth; they are the primary cause for catastrophic failure.

The best way to control impact is to reduce the load inertia as much as feasible and then to limit its angular velocity. Determine the dwell time needed at the work station, then use as much as possible of the remaining time for transport by controlling rotational speed with flow control of the exhausting cylinder.

External stops, with or without shock absorbers, should be used in severe actuator installations. If external stops are not practical, auxiliary cylinders and pistons with an adjustable external air supply can be fitted to absorb load energy. Internal cushions will quiet a light load but will not dissipate a significant amount of load energy.

For an indexer, external shock absorbers can be effective if properly installed to allow full angular travel of the load.

ACTUATOR ROTATION AND POSITION ACCURACY

The tolerance of the angle of shaft rotation is shown in the table on page 5. The tolerance on keyway position at the ends of rotation is one-half of the rotation tolerance plus one degree. For example, an A3-90-CW... shaft will rotate through 90 to 92 deg. (-0° +2° tolerance). Its keyway will start between 358° and 0° (1/2 x 2° + 1° tolerance) and will finish rotation between 90° and 92° (1/2 x 2° + 1° tolerance).

BACKLASH IN ACTUATORS

Rotomation dual rack actuators are arranged so that at the end of stroke the tooth backlash distance is taken up by one-half the unit torque. Order the dual rack configuration to achieve this position accuracy without external stops.

In single rack actuators there is ordinarily some backlash at the ends of rotation. See table, page 5 for maximum values.

CONTROL COMBINATIONS

Not all controls can be combined at one end of a cylinder. Combinations of controls are possible in a two rack unit which provide functional and access advantages. Combination of flow control and cushion or cushion and rotation adjuster can be set up on different racks, can be placed at one end or the other to improve access or installation arrangements.

TORQUE REQUIREMENT

Specification of an actuator or other rotary device should begin with the load torque requirement with margin to account for variations in load, system pressure at the actuator and friction in the actuator (See "Breakaway Friction"). Actuator and load static friction occur at the start of the cycle and must be allowed for. Load torque should be measured rather than computed to avoid errors from unanticipated factors. Temporary torque arms and "fish scale" force measurements will usually suffice. With the load torque known, a device can be specified on the basis of minimum system pressure and a reasonable margin; 40% is used by many designers to assure reliable production.

BREAKAWAY FRICTION

The pressure energized nitrile seals used allow breakaway at low pressure. Actuators and steppers start and move smoothly at or below 5 psi, indexers below 7 psi, and pick and place and nitpicker units below 15 psi. Pretensioned seals or seals of FKM increase this pressure to as much as 25 psi.

DUAL RACK INDEXING AND STEPPING ACTUATORS

Many applications involve moving a load which is primarily inertia. In this case, the limiting factor for an indexing actuator is its ability to stop the load. The only reason to specify a dual rack actuator is for an application with a high torque, low inertia load, such as friction, bending, or lifting.

INDEXING AND STEPPING ACTUATOR TORQUE RATINGS

The maximum torque is limited by the roller clutches used to drive the shaft and to prevent reverse rotation. Exceeding the maximum working pressure specified may overload the clutch, reducing life and/or causing immediate failure. Dual rack actuators are intended for use in applications where the maximum torque rating of the clutch cannot be utilized on normal shop air. Please note that normal shop air may overload the clutch on a dual rack indexing or stepping actuator. Reverse torque from an external source can also damage the actuator if it exceeds the maximum torque rating.

MAXIMUM OPERATING RATES

Rotomation devices are capable of operating at rates as high as hundreds of cycles per minute, but the angular momentum of most loads will limit the usable rate. See "Actuator and Indexer Shock Loads". System and cycle design should begin with identification of the total amount of time available for load transport, allowing necessary dwell time for machine or manual operations. With the cycle set up to utilize this time, the load motion can be slowed as far as possible and the effects of load velocity minimized. Especially with high cycle rates, it is wise to limit impact velocity by use of flow control in the exhausting cylinder or by lowered system pressure. Impacts which cause torsional vibration or bounce will generally cause failure of parts.

PHONE & FAX SUPPORT

For technical support and additional information, call 386-676-6377 or fax 386-676-6379.

READY REFERENCE - CONTINUED

PNEUMATIC OPERATION AND LUBRICATION

With clean air, normal loading and noncorrosive environment, Rotomation actuators will operate for millions of cycles without added lubrication. For maximum life with high cycle rates and/or less clean environment, the heavy duty (A, K or J) options should be specified and/or airline lubrication utilized. Lubricators should be appropriately sized, positioned to allow downward flow to the actuator and kept filled with lubricant compatible with the seals in use.

FLUID MEDIUM AND SEALS

Use a good, clean fluid compatible with the seals in dynamic applications. Seals are of nitrile (Buna) unless specified otherwise; check the fluid in use. If other seals materials have been specified, particular attention is required. Polyurethane, used in pretensioned seals, is not compatible with automatic transmission fluid and a number of widely used petroleum based fluids. Where high temperature or aggressive fluids (as phosphate esters) are encountered, specify fluorocarbon seals. Pretensioned seals and some seal compounds cause increased cylinder friction, raising the breakaway pressure to as much as 25 psi.

OIL LEAKAGE

Hydraulic units will, in general, suffer some leakage. Piston seal leakage will be apparent ultimately as leakage from the body, and will occur in either air/oil or hydraulic installations. The amount is usually small, resulting from the relaxation of the seal when pressure is removed, either during normal cycling or shutdown. This oil can be disposed of by the installation of a drain connection to the body which will be supplied upon request; specify mount orientation for correct location. Pretensioned seals will markedly reduce leakage. However, these seals increase breakaway pressure as much as 25 psi, which is negligible in most hydraulic systems but is not tolerable in some air/oil applications. Multiple seals may be effective in some instances. Consult the factory.

AIR/OIL INSTALLATIONS

Air/oil systems provide close control and smooth motion but operate at relatively low rotation rates unless large passages and valves are provided for high flow rates at low pressure differentials. Conventional air/oil systems use air/oil tank for each direction with a flow control in each air or oil line, depending upon the degree of control required. Slow, uniform motion in one direction and faster motion in the other can be achieved using an air/oil tank and cylinder on one side, and straight air, flow controlled in exhaust, on the other side. Seals and fluid should be carefully selected to achieve desired motion and leak characteristics.



FLOATING PISTONS

Floating pistons provide many operating advantages, they may require special attention during set up when the shaft is moved manually without pressure in the cylinders to keep the pistons against the ends of the rack; the pistons often stick against the end caps, leaving the rack free. The result is that the piston will make a noisy impact against the rack when pressure is applied. In case of a unit with magnetic pistons, the uncertainty of piston location can lead to errors in setting the operating point of magnetic switches; use a low pressure to retain the pistons if manual positioning is required. All Rotomation units except the following have floating pistons: A032, A01, A1, S1, X1, X12, AL75, A752 and PA01; these units have captive pistons.

INTERNAL LUBRICATION

The internal lubrication applied in factory assembly will ordinarily last the life of the unit. Only if the unit is operated at extreme rates or is subject to temperatures high enough to cause displacement of the grease should added lubrication be required. 1/2 to 1 teaspoon of general purpose lithium based grease may be placed on the rack teeth and cylinders at the time of installation of replacement seals or other repair. The cylinders and seals are lubricated in assembly with a lithium based grease containing suspended PTFE.

NOTE: Units manufactured prior to early 1987 had grease fittings or plugs. These have been eliminated to avoid possibility of jamming the unit by excess lubricant.

LOAD COUPLING

The load hub should fit the shaft closely and the key be of correct size and length to make a firm fit using all available keyway length. Tighten the set screw over the key firmly, retaining its position with thread locking adhesive.

ADJUSTABLE LOAD COUPLING

For a hard coupling allowing angular adjustment of the load position, a self-locking coupling (Ringfeder, etc.) can be used directly on the Rotomation and using shafts. Couplers must be carefully installed and tightened; they require wrench clearance and precise shaft alignment.

MOUNTING AND ALIGNMENT

Where possible, provide a compliant coupling between the Rotomation unit and its load. If a hard coupling to a firmly supported shaft is required, provide adjustment of the angle and position of the Rotomation shaft using shims, slotted holes or other means. With mount screws installed and at intended torque, test for free rotation of the shaft and unit. See "Hollow Shaft" below.

HOLLOW SHAFT ACTUATOR INSTALLATION

For a compact, self-aligning installation, place the hollow shaft actuator over the driven shaft, allowing the weight of the actuator to be carried by the shaft and its bearings. Arrange a turnbuckle to take the actuator torque by attaching one end to the actuator by a bracket to mount holes, and the other to the using assembly. The actuator thus remains in alignment with the shaft; adjust the turnbuckle to set the keyway position precisely.

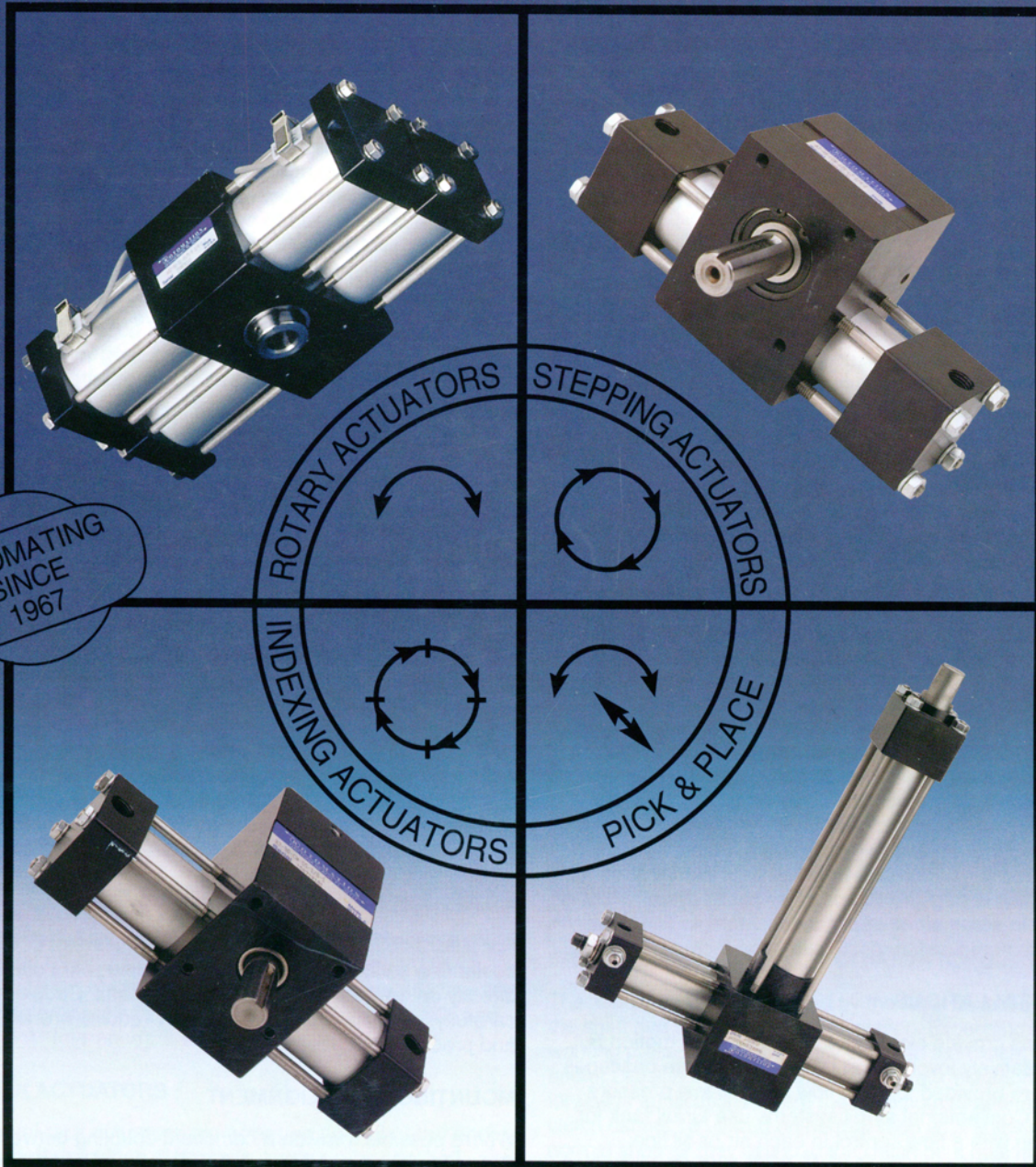

AUTOMATING
SINCE
1967

ROTOMATION

11 SUNSHINE BOULEVARD
 ORMOND BEACH, FLORIDA 32174
 TELEPHONE: (386) 676-6377
 FAX: (386) 676-6379
 E-Mail: sales@rotomation.com
 Web: www.rotomation.com