

p-RELS Series: Premium Rod-End Load Sensor

RELS Series sensors are mounted directly to the rod-end of a cylinder, situating the measurement device in an ideal position: directly within the load chain and immediately adjacent to the loading event.

The Premium RELS enhances performance by offering significantly improved accuracy, repeatability, off-axis / eccentric load compensation, and temperature compensation.

Benefits of Direct Force Measurement vs Pressure-Derived Load Estimates

- Excellent Accuracy and Sensitivity
- Improved Reproducibility and Repeatability
- Low Latency, Immune to Cylinder Friction
- Temperature Compensated
- Measurement is NIST Traceable

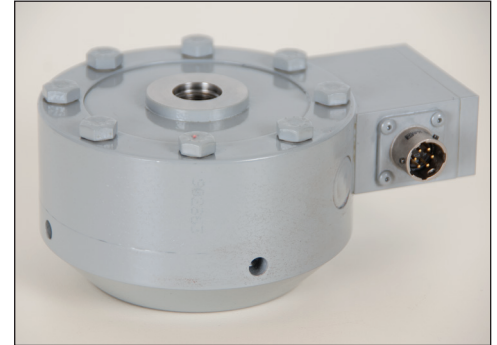

Key Applications

- Direct Input to Delta Computer Systems and other PLC platforms
- Accurate, Reproducible and Sensitive Force Measurements
- Extreme Repeatability of Displacement Measurements for Servo Control
- High Speed Measurements / Data Logging
- Calibration Reference for Pressure-Measurement-Based Systems

PERFORMANCE SPECIFICATIONS

	Part Number	Full Scale (±lbf)	Combined Error (±lbf)	Non-Repeatability (±lbf)	Eccentric Load Sensitivity (%RDG / in)	Min Rod Ø (in)	Deflection (in / FS)
Standard Sensor Capacities	p-RELS-5K	5,000	3.5	0.5	0.25	1 3/8	0.002
	p-RELS-10K	10,000	7	1		0.003	
	p-RELS-25K	25,000	20	2.5			2 1/2
	p-RELS-50K	50,000	40	5			3
	p-RELS-100K	100,000	100	10			4 1/2
	p-RELS-200K	200,000	240	20			6
	p-RELS-400K	400,000	680	80			7 3/4
	p-RELS-600K	600,000	1,200	120			10 1/2
	p-RELS-1M	1,000,000	2,500	200			14
	p-RELS-2M	2,000,000	7,000	400			

Additional capacities available upon request. %RDG: percent of applied load. 5-Points bidirectional NIST / ISO 17025 Accredited Calibration included. FS: full scale, the capacity of the sensor. Min Rod Diameter: Recommended to fully support load cell in compressive loading.

MECHANICAL		
Safe Overload	150	± %FS
Enhanced SO (option)	300	

NAMING SCHEME: Modifier-Series-Capacity-Output
EXAMPLE: p-RELS-100K-V

THERMAL		
Compensated Range	15 to 115	°F
Operating Range	-65 to 200	
Effect on Output	0.0008	%FS / °F

Signal Output Selection	PN Suffix	Output At			Power Supply	
		Tension FS	Zero	Compression FS	VDC	mA
	-V	-10 V	0 V	+10 V	11.5 – 26	24
-A	4 mA	12 mA	20 mA			

Other output types available upon request.

RESPONSE		
Dynamic	1000	Hz
Bandwidth	1	ms

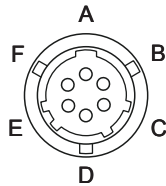
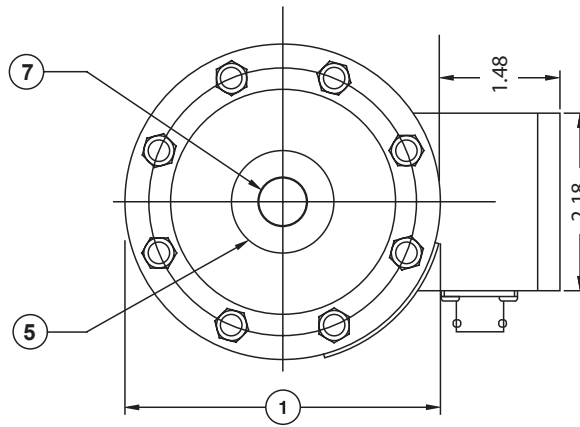
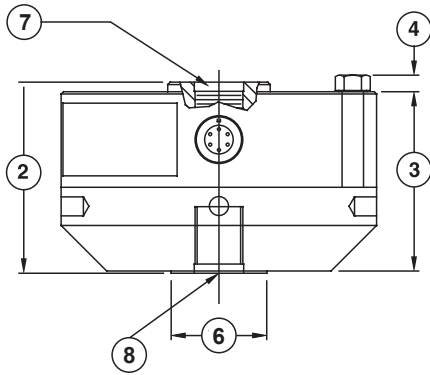

Connector: PT02E-10-6P	
Pin	Function
A	+ Supply
B	Supply Ground
C	Output Ground
D	+ Output
E	Shunt Cal
F	Shunt Cal

DIMENSIONS (in)

Description	①	②	③	④	⑤		⑦		⑧
	Body Ø	Total Length	Body Length	Cap Head Height	Loading Surface Ø		Thread Type (UNF) x Depth		Mounting
					Active	Mounting	Active	Mounting	
p-RELS-5K	4.13	2.51	2.38	0.20	1.34	1.25	5/8-18 F x 1.12	5/8-18 F x 0.87	
p-RELS-10K	4.13	2.51	2.38	0.20	1.34	1.25	5/8-18 F x 1.12	5/8-18 F x 0.87	
p-RELS-25K	6.06	3.50	3.38	0.30	2.65	2.25	1 1/4-12 F x 1.40	1 1/4-12 F x 1.40	
p-RELS-50K	6.06	3.50	3.38	0.30	2.65	2.25	1 1/4-12 F x 1.40	1 1/4-12 F x 1.40	
p-RELS-100K	8.00	4.50	4.25	0.40	3.76	3.00	1 3/4-12 F x 2.15	1 3/4-12 F x 1.75	
p-RELS-200K	11.00	6.50	6.00	0.50	4.81	4.50	2 3/4-8 F x 2.75	2 3/4-8 F x 2.75	
p-RELS-400K	12.00	9.00	8.75	0.59	6.18	6.00	3 1/2-8 F x 4.13	3 1/2-8 F x 3.75	
p-RELS-600K	15.50	10.50	10.00	0.69	7.73	7.75	4 1/4-8 F x 4.25	4 1/4-8 F x 4.25	
p-RELS-1M	20.50	13.25	13.00	1.00	10.55	10.55	6-8 F x 5.63	6-8 F x 6.38	
p-RELS-2M	26.00	16.75	16.50	1.25	13.79	14.00	8-8 F x 7.00	8-8 F x 7.25	