

Machine Tool Hydraulics That Run Steadier and Commission Faster

Your Machine Isn't Failing. It's Quietly Losing Accuracy.

It doesn't crash. It doesn't alarm. It just slowly starts missing.

Clamp drift. Pressure variation. Heat creep.

And before anyone notices, you're chasing scrap, rework, and inconsistency.

Hydraulic issues accumulate over time:

- Pressure variation that becomes scrap
- Heat-related viscosity changes that become inconsistent with cycle performance
- Messy integration that becomes long startups and recurring troubleshooting**

When that happens, off-the-shelf approaches hit their ceiling, because the real requirement isn't "a power unit." **It's repeatable machine performance.**

This is where most systems break down.

Not because of one bad component but because **the system wasn't designed to stay stable under real conditions.** And once instability shows up, it spreads across the machine with **longer cycle times, operator adjustments, ongoing troubleshooting,** etc.

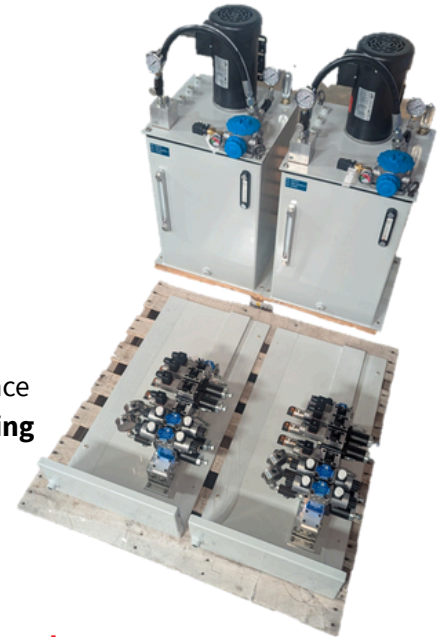

Why Most Hydraulic Systems Struggle and What We Do Differently

Most systems are designed to "work." We design them to **stay stable.**

1	2	3
PHYSICS-FIRST DESIGN	INTEGRATION-FIRST PACKAGING	QUALITY-FIRST BUILD
<p>We start with load, duty cycle, holding requirements, pressure stability, and thermal behavior. Then engineer the circuit and architecture to match.</p> <p>WHAT YOU GET</p> <ul style="list-style-type: none"> Stable pressure behavior under real cycling Leak-resistant holding where it matters most Independent control so stations/functions don't fight each other 	<p>Hydraulics live alongside wiring, structure, guarding, service access, and real-world operators. We design for footprint, access, wiring strategy, and serviceability from the start.</p> <p>WHAT YOU GET</p> <ul style="list-style-type: none"> Cleaner installs, fewer surprises, faster startups OEM-friendly interfaces (connectors, labels, I/O options) Architectures that fit the machine, not the other way around 	<p>Systems are assembled and tested at Donald Engineering prior to shipment, with repeat-build discipline when needed.</p> <p>WHAT YOU GET</p> <ul style="list-style-type: none"> Reduced startup risk Consistent performance from unit to unit Confidence it works on day one



The Right Solution Depends on What's Failing

Not every hydraulic problem comes from the same place. Some machines need a stable power foundation. Others need tighter control. And some require working together without fighting each other.

That's why we design around **how** your machine actually behaves.

1 Stand-Alone Custom Hydraulic Power Units

For machines that require a dedicated power foundation, we engineer stand-alone custom Hydraulic Power Units designed for stability, serviceability, and clean integration.

What this solves:

- Unstable pressure during cycling
- Heat-driven performance drift
- Inconsistent system response

How we design it:

- Hydraulic sizing & circuit design based on real duty cycle
- Air-driven (air/oil) or electric motor-driven configurations
- Custom reservoir, top-plate, and component layout for access and service
- Filtration strategies with visual/electric contamination indicators
- Pressure monitoring (transducers, gauges, snubbers, isolation valves)
- Level and temperature monitoring
- Custom drip pans/containment solutions
- Custom paint options to match machine frame standards
- Fully assembled and tested before shipment

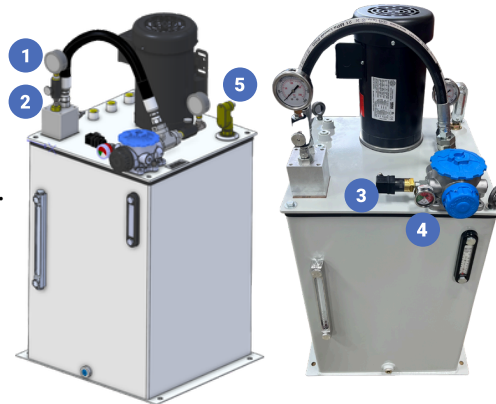

1. Liquid-filled pressure gauges
2. Isolation valves
3. Electric contamination indicator
4. Visual contamination indicator
5. Level & temperature monitoring

2 Custom Manifold Assemblies (Integrated to HPU or Remote/Machine-Mounted)

When control, routing, and holding precision start breaking down, the issue is usually in how the system is distributed. Manifolds simplify the system, reduce leak paths, and give you tighter control where it matters most.

What this solves:

- Excess leak points from fittings and plumbing
- Inconsistent clamping or holding pressure
- Slow response or poor flow control

How we design it:

- Custom hydraulic schematic + manifold circuit design
- 3D CAD packaging for clean integration into the machine
- Remote or HPU-mounted manifolds based on routing and response needs
- **Low-leak poppet valve strategies for critical holding**
- Modular stack valves for independent station control
- High-pressure workholding solutions (pumps, intensifiers)
- Integrated pressure/flow monitoring for validation and troubleshooting

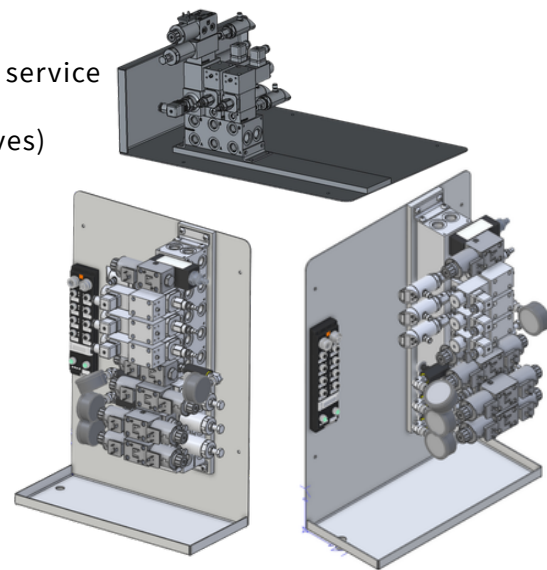

Remote Mount Manifold

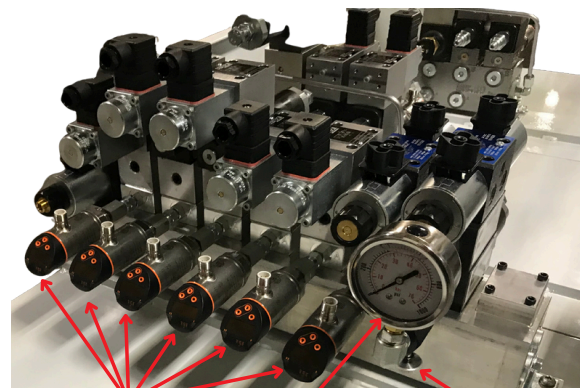

- Pressure Sensors
- Liquid-filled pressure gauges
- Isolation valves

3 Custom HPU + Manifold Combinations (Integrated or Remote)

For machines that demand **both hydraulic power and precise control in a unified package**, we engineer complete HPU + manifold combinations.

These are fully integrated hydraulic “modules” designed as part of the machine, combining power, control, and monitoring into a clean, commission-ready architecture.

What this solves:

- Mismatch between power unit and control system
- Complex wiring and long commissioning time
- Integration issues between hydraulic and electrical systems

How we design it:

- Fully integrated hydraulic “modules” (power + control + monitoring)
- Manifold-on-HPU or remote manifold configurations
- Single connection point/junction box options to simplify installation
- Wiring to customer-specified I/O modules for straightforward OEM integration
- Installation of customer-specified connectors on switches, solenoids, and motors
- VFD integration (where applicable)
- Custom labels and identification for faster startup and service
- Build guides and quality checklists for repeat assemblies
- Fully assembled and tested at Donald Engineering before shipping

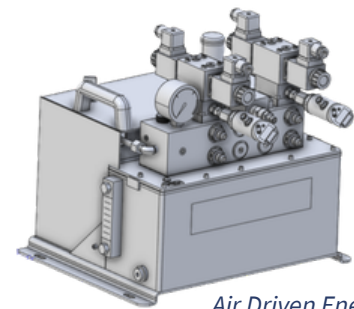
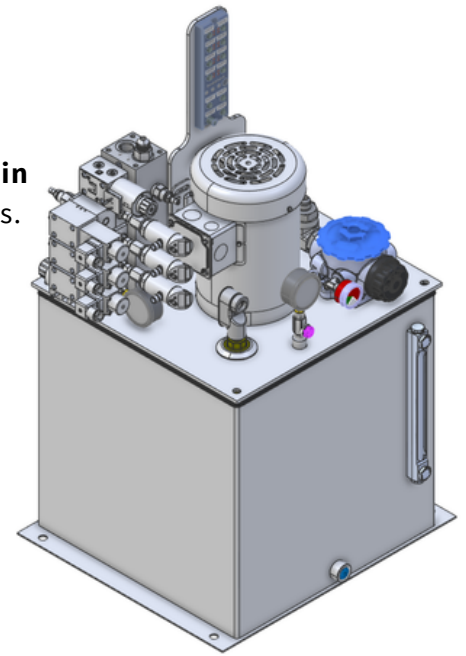

*Air Driven Enerpac
Durotech HPU*

Monitoring, Protection, and Serviceability Options

A stable system doesn't help if you can't see what it's doing.

That's why we integrate monitoring, protection, and serviceability options that reduce troubleshooting time and long-term risk.

Built-in visibility includes:

- Pressure, flow, level, and temperature monitoring (digital or analog)
- Gauges with isolation shut-off for safe verification
- Contamination indicators to catch issues before damage occurs
- Layout and labeling designed to reduce troubleshooting time

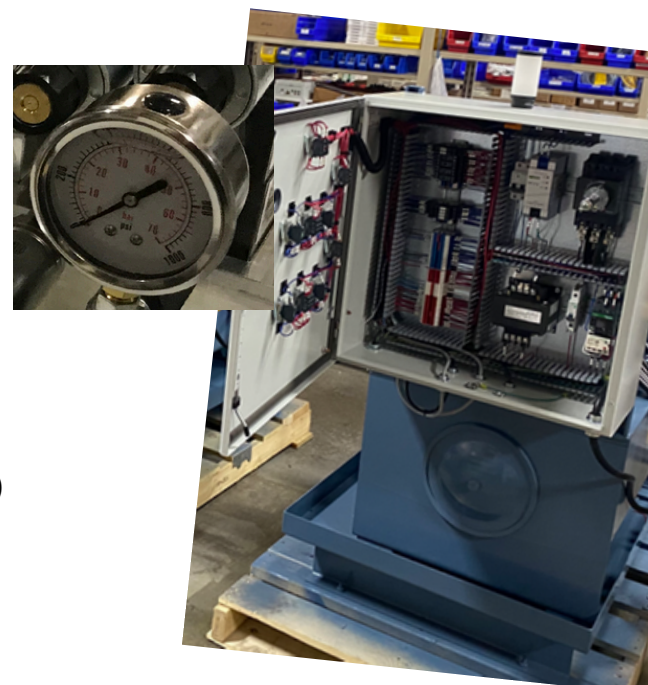

What This Means for You

When hydraulics are designed this way, you don't just get a system that runs, you get a system that behaves.



What that looks like on your machine:

- Consistent clamping and holding*
- Predictable cycle performance*
- Fewer startup surprises*
- Less time spent troubleshooting*
- Confidence the machine will run the same over time*



This is the difference between a system that "runs"... and one you can rely on.

Custom machine tool hydraulic systems require more than components; they require an engineering partner.

At Donald Engineering, we design systems to reduce risk, simplify integration, and support long-term machine performance. Stuck chasing drift, leaks, or inconsistent performance? Let's fix the root cause.

Hydraulic Vendor Partners



The Donald Engineering Difference

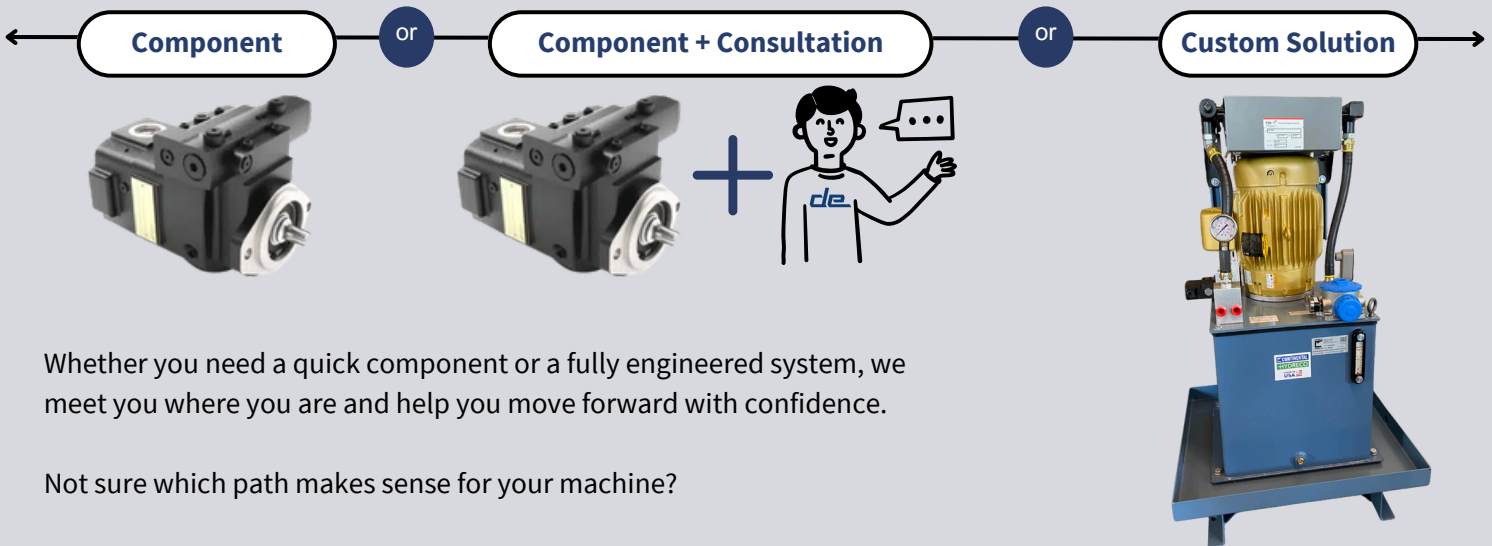

Whether you need a quick component or a fully engineered system, we meet you where you are and help you move forward with confidence.

Not sure which path makes sense for your machine?

Let's take a look. We'll help you figure out what's actually causing the issue, and what it takes to fix it.

Contact our Sales Engineering team today to get started!

sales@donaldengineering.com

(616) 538-8340

